

NEET 2023

Physics

Question 1: The minimum wavelength of X-rays produced by an electron accelerated through a potential difference of V volts is proportional to:

Options:

- (a) \sqrt{V}
- (b) $\frac{1}{V}$
- (c) $\frac{1}{\sqrt{V}}$
- (d) V^2

Answer: (b)

Solution: Minimum cut of wavelength $\lambda \propto \frac{1}{V}$

Question 2: A carnot engine has an efficiency of 50% when its source is at a temperature 327°C . The temperature of the sink is:

Options:

- (a) 27°C
- (b) 15°C
- (c) 100°C
- (d) 200°C

Answer: (a)

Solution: $\eta = 1 - \frac{T_{\text{SINK}}}{T_{\text{SOURCE}}}$

$$\frac{1}{2} = 1 - \frac{T_{\text{SINK}}}{600}$$

$$\frac{T_{\text{SINK}}}{600} = 1 - \frac{1}{2} = \frac{1}{2}$$

$$T_{\text{SINK}} = 300\text{K or } 27^\circ\text{C}$$

Question 3: A bullet is fired from a gun at the speed of 280ms^{-1} in the direction 30° above the horizontal. The maximum height attained by the bullet is ($g = 9.8\text{ms}^{-2}$, $\sin 30^\circ = 0.5$):

Options:

- (a) 2800 m
- (b) 2000 m
- (c) 1000 m
- (d) 3000 m

Answer: (c)

Solution: $H = \frac{U^2 \sin^2 \theta}{2g}$

$$\begin{aligned}
 &= \frac{280 \times 280 \sin^2 30}{2 \times 9.8} \\
 &= \frac{280 \times 280 \times 1}{2 \times 9.8 \times 4} = 1000 \text{ m}
 \end{aligned}$$

Question 4: In a series LCR circuit, the inductance L is 10 mH, capacitance C is $1\mu F$ and resistance R is 100Ω . The frequency at which resonance occurs is:

Options:

- (a) 15.9 rad/s
- (b) 15.9 kHz
- (c) 1.59 rad/s
- (d) 1.59 kHz

Answer: (d)

Solution: $f = \frac{1}{2\pi} \sqrt{\frac{1}{\lambda C}}$

$$\begin{aligned}
 &= \frac{1}{2\pi} \sqrt{\frac{1}{10 \times 10^{-3} \times 1 \times 10^{-6}}} \\
 &= \frac{1}{2\pi} \sqrt{\frac{1}{10^{-8}}} \\
 &= \frac{10^4}{2\pi} \\
 &= \frac{\pi \times 10^4}{2\pi^2} \\
 &= \frac{\pi}{2} \times 10^3 \\
 &= \frac{3.14}{2} \times 10^3 \\
 &= 1.59 \times 10^3 \\
 &= 1.59 \text{ kHz}
 \end{aligned}$$

Question 5: Given below are two statements:

Statement I: Photovoltaic devices can convert optical radiation into electricity.

Statement II: Zener diode is designed to operate under reverse bias in breakdown region.

In the light of the above statements, choose the most appropriate answer from the options given below:

Options:

- (a) Both Statement I and Statement II are correct.
- (b) Both Statement I and Statement II are incorrect.
- (c) Statement I is correct but Statement II is incorrect
- (d) Statement I is incorrect but Statement II is correct.

Answer: (a)

Solution: BOTH STATEMENTS ARE CORRECT

Question 6: Light travels a distance x in time t_1 in air and $10x$ in time t_2 in another denser medium. What is the critical angle for this medium?

Options:

- (a) $\sin^{-1} \left(\frac{t_2}{t_1} \right)$
 (b) $\sin^{-1} \left(\frac{10t_2}{t_1} \right)$
 (c) $\sin^{-1} \left(\frac{t_1}{10t_2} \right)$
 (d) $\sin^{-1} \left(\frac{10t_1^2}{t_2^2} \right)$

Answer: (d)

Solution: Using Snell's law

$$\mu_1 v_1 = \mu_2 v_2$$

in a medium

$$\frac{x}{t_1} = \mu_2 \frac{10x}{t_2}$$

$$\mu_2 = \frac{t_2}{10t_1}$$

$$\sin C = \frac{1}{\mu_2} = \frac{1}{\frac{t_2}{10t_1}}$$

$$= \frac{10t_1}{t_2}$$

$$C = \sin^{-1} \left(\frac{10t_1}{t_2} \right)$$

Question 7: In hydrogen spectrum, the shortest wavelength in the Balmer series is λ . The shortest wavelength in the Brackett series is:

Options:

- (a) 2λ
 (b) 4λ
 (c) 9λ
 (d) 16λ

Answer: (b)

$$\text{Solution: } \frac{1}{\lambda} = R \left[\frac{1}{n_2^2} - \frac{1}{n_1^2} \right]$$

For Balmer

$$\frac{1}{\lambda} = R \left[\frac{1}{2^2} - \frac{1}{\infty} \right]$$

$$\frac{1}{\lambda} = \frac{R}{4}$$

$$\lambda = \frac{4}{R}$$

For Brackett

$$\frac{1}{\lambda'} = R \left[\frac{1}{4^2} - \frac{1}{9^2} \right]$$

$$= \frac{R}{16} \left[\frac{9^2 - 4^2}{9^2 \cdot 4^2} \right]$$

$$\lambda' = \frac{16}{R} \cdot \frac{16}{4} = 4\lambda$$

Question 8: If the galvanometer G does not show any deflection in the circuit shown, the value of R is given by:

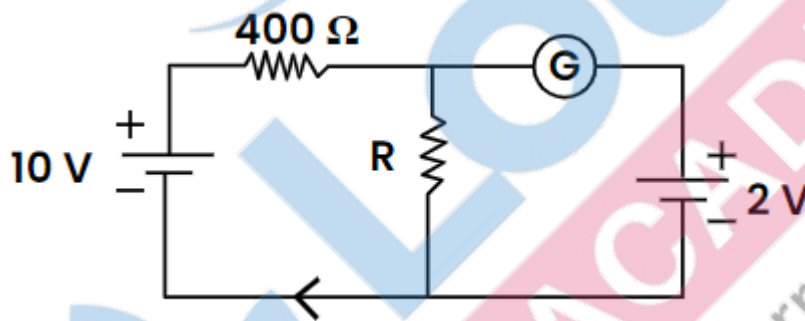

Options:

- (a) 200Ω
- (b) 50Ω
- (c) 100Ω
- (d) 400Ω

Answer: (c)

Solution: $I = \frac{8}{400} = \frac{1}{50} \text{ amp}$

V across R

$$V = IR$$

$$2 = \frac{1}{50} \times R$$

$$R = 100\Omega$$

Question 9: The amount of energy required to form a soap bubble of radius 2 cm from a soap solution is nearly: (Surface tension of soap solutions = 0.03 N m^{-1})

Options:

- (a) $30.16 \times 10^{-4} \text{ J}$
- (b) $5.06 \times 10^{-4} \text{ J}$
- (c) $3.01 \times 10^{-4} \text{ J}$
- (d) $50.1 \times 10^{-4} \text{ J}$

Answer: (c)

Solution: Surface energy of bubble = $2[T \cdot \text{Area}]$

$$= 0.03 \times 4\pi r^2 \times 2$$

$$= 0.03 \times 4\pi \times (2 \times 10^{-2})^2 \times 2$$

$$= 0.03 \times 16\pi \times 10^{-4} \times 2$$

$$= 16\pi \times 10^{-4} \times 0.03 \times 2$$

$$= 16\pi \times 10^{-4} \times 0.03 \times 2$$

$$= 48\pi \times 10^{-6} \times 2$$

$$= 150.72 \times 10^{-6} \times 2$$

$$= 301.44 \times 10^{-6}$$

$$= 3.01 \times 10^{-4} J$$

Question 10: The magnetic energy stored in an inductor of inductance $4\mu H$ carrying a current of 2A is:

Options:

(a) $4\mu J$

(b) 4mJ

(c) 8mJ

(d) $8\mu J$

Answer: (d)

Solution: $1J = \frac{1}{2} Li^2$

$$= \frac{1}{2} \times 4 \times 10^{-6} \times (2)^2$$

$$= 8 \times 10^{-6} J$$

$$= 8\mu J$$

Question 11: A 12V, 60W lamp is connected to secondary of step down transformer, whose primary is connected to ac mains of 220V. Assuming the transformer to be ideal, what is the current in the primary winding?

Options:

(a) 0.27 A

(b) 2.7 A

(c) 3.7 A

(d) 0.37 A

Answer: (a)

Solution: Since the transformer is ideal,

$$P_{input} = P_{output}$$

$$220 \times I_{input} = 60$$

$$I_{input} = \frac{60}{220} = 0.27 A$$

Question 12: An electric dipole is placed at an angle of 30° with an electric field of intensity $2 \times 10^5 NC^{-1}$. It experiences a torque equal to 4Nm. Calculate the magnitude of charge on the dipole, if the dipole length is 2 cm.

Options:

- (a) 8 mC
- (b) 6 mC
- (c) 4 mC
- (d) 2 mC

Answer: (d)

Solution: $|\vec{\tau}| = \rho E \sin \theta$

$$4 = (ql) E \sin 30^\circ$$

$$4 = q \times \frac{2}{100} \times 2 \times 10^5 \times \frac{1}{2}$$

$$q = 2 \times 10^{-3} C = 2mC$$

Question 13: A vehicle travels half the distance with speed v and the remaining distance with speed $2v$. Its average speed is

Options:

- (a) $\frac{v}{3}$
- (b) $\frac{2v}{3}$
- (c) $\frac{4v}{3}$
- (d) $\frac{3v}{4}$

Answer: (c)

Solution:

Question 14: Let a wire be suspended from the ceiling (rigid support) and stretched by a weight W attached at its free end. The longitudinal stress at any point of cross-sectional area A of the wire is:

Options:

- (a) $\frac{2W}{A}$
- (b) $\frac{W}{A}$
- (c) $\frac{A}{W}$
- (d) $\frac{2A}{W}$

(d) Zero

Answer: (b)

Solution:



$$\text{Longitudinal stress} = \frac{\text{Force}}{\text{Area}} = \frac{W}{A}$$

Question 15: If $\oint_s \vec{E} \cdot d\vec{S} = 0$ over a surface, then:

Options:

- (a) the number of flux lines entering the surface must be equal to the number of flux lines leaving it.
- (b) the magnitude of electric field on the surface is constant
- (c) all the charges must necessarily be inside the surface.
- (d) the electric field inside the surface is necessarily uniform.

Answer: (a)

Solution:

$$\oint \vec{E} \cdot d\vec{S} = 0$$

\Rightarrow Net flux through the closed surface is 0.

\therefore No. of field lines entering = No. of field lines leaving

Question 16: The work functions of Caesium (Cs), Potassium (K) and Sodium (Na) are 2.14 eV, 2.30 eV and 2.75 eV respectively. If incident electromagnetic radiation has an incident energy of 2.20 eV, which of these photosensitive surfaces may emit photoelectrons?

Options:

- (a) Cs only
- (b) Both Na and K
- (c) K only
- (d) Na only

Answer: (a)

Solution: For photoelectric effect to take place,

$$E_{\text{Incident radiations}} > \text{Work functions.}$$

Question 17: The temperature of gas is -50°C . To what temperature the gas should be heated so that the rms speed is increased by 3 times?

Options:

- (a) 669°C
- (b) 3295°C
- (c) 3097 K
- (d) 223 K

Answer: (b)

Solution: Initial temperature = $-50^{\circ}\text{C} = 223\text{K}$

$$\text{Initial rms speed} = \sqrt{\frac{3R(223)}{M}}$$

Now, the rms speed should be increased by 3 times.

$$\therefore \text{Final } \vartheta_{rms} = \vartheta + 3\vartheta = 4[\vartheta_{rms\text{initial}}]$$

$$\therefore \sqrt{\frac{3RT_2}{M}} = 4\sqrt{\frac{3R(223)}{M}}$$

$$T_2 = 3568\text{K}$$

$$= 3295^{\circ}\text{C}$$

Question 18: The ratio of frequencies of fundamental harmonic produced by an open pipe to that of closed pipe having the same length is:

Options:

- (a) 1 : 2
- (b) 2 : 1
- (c) 1 : 3
- (d) 3 : 1

Answer: (b)

Solution: Fundamental frequency of open pipe = $\frac{v}{2L}$

Fundamental frequency of closed pipe = $\frac{v}{4L}$

$$\text{Ratio: } \frac{v}{2L} \times \frac{1}{\frac{v}{4L}} = 2:1$$

Question 19: Resistance of a carbon resistor determined from colour codes is $(22000 \pm 5\%) \Omega$

. The colour of third band must be:

Options:

- (a) Red
- (b) Green
- (c) Orange
- (d) Yellow

Answer: (c)

Solution: $(22000 \pm 5\%) \Omega$

$$(22 \times 10^3 \pm 5\%) \Omega$$

First digit: 2 → Red

Second digit: 2 → Red

Multiplier: 10^3 → Orange

Tolerance: 5% → Gold

Question 20: For Young's double slit experiment. two statements are given below:

Statement I: If screen is moved away from the plane of slits, angular separation of the gas remains constant.

Statement II: If the monochromatic source is placed by another monochromatic source of larger wavelength, the angular separation of fringes decreases.

In the light of the above statements, choose answer from the options given below:

Options:

- (a) Both Statement I and Statement II are true.
- (b) Both Statement I and Statement II are false
- (c) Statement I is true but Statement II is false
- (d) Statement I is false but Statement II is true.

Answer: (b)

Solution: Both Statement I and Statement II are false

$$\text{Angular separation between the fringes} = \frac{\text{Fringe Width}}{D} = \frac{\beta}{D} = \frac{\lambda}{d}$$

∴ Moving the screen away, i.e. increasing D, will not affect the angular separation.

Also, on increasing wavelength, angular separation increases.

Question 21: A metal wire has mass $(0.4 \pm 0.002) g$, radius $(0.3 \pm 0.001) mm$ and length $(5 \pm 0.02) cm$. The maximum possible percentage error in the measurement of density will nearly be:

Options:

- (a) 1.2%
- (b) 1.3%
- (c) 1.6%
- (d) 1.4%

Answer: (c)

Solution: $m = (0.4 \pm 0.002) g$

$$r = (0.3 \pm 0.001) mm$$

$$l = (5 \pm 0.02) cm$$

$$\delta = \frac{\Delta m}{m} = \frac{\Delta \delta}{\delta} \Rightarrow \frac{\Delta \delta}{\delta} = \frac{\Delta m}{m} + \frac{2\Delta r}{r} + \frac{\Delta l}{l}$$

$$= \frac{0.002}{0.4} + 2 \times \frac{0.001}{0.3} + \frac{0.02}{5}$$

$$= \frac{0.02}{4} + \frac{0.02}{3} + \frac{0.02}{5}$$

$$= 0.02 \left(\frac{15 + 20 + 12}{60} \right)$$

$$= 0.02 \times \frac{47}{60}$$

$$= 0.02 \times 0.783$$

$$= 0.0156$$

$$\frac{\Delta \delta}{\delta} \times 100 = 1.56\% \approx 1.6\%$$

δ

Question 22: The equivalent capacitance of the system shown in the following circuit is:

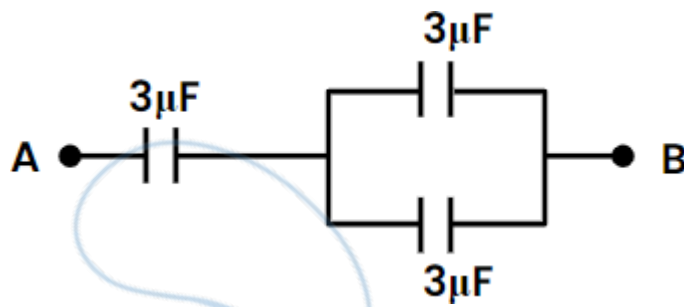

Options:

(a) $2\mu F$

(b) $3\mu F$

(c) $6\mu F$

(d) $9\mu F$

Answer: (a)

Solution:

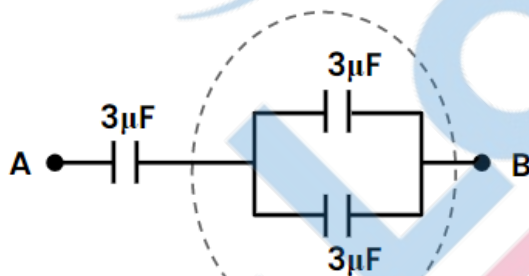

Parallel
($3+3 = 6\mu F$)



Series

$$C_{eq} = \frac{3 \times 6}{3 + 6} = \frac{18}{9} = 2\mu F$$

Question 23: Two bodies of mass m and $9m$ are placed at a distance R . The gravitational potential on the line joining the bodies where the gravitational field equals zero, will be ($G =$ gravitational constant):

Options:

(a) $-\frac{8Gm}{R}$

(b) $-\frac{12Gm}{R}$

(c) $-\frac{16Gm}{R}$

$$(d) \frac{20Gm}{R}$$

Answer: (c)

Solution:

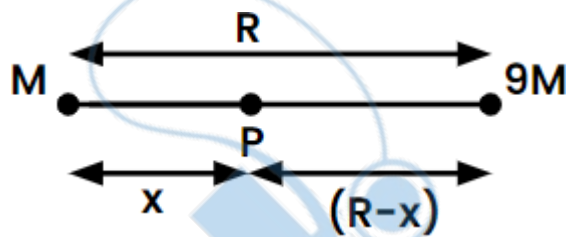

Let gravitational field at point P is zero. Which is situated at distance x from mass m.

$$\therefore \frac{Gm}{x^2} = \frac{G(9m)}{(R-x)^2}$$

Square root both sides

$$\frac{1}{x} = \frac{3}{R-x}$$

$$R-x = 3x$$

$$R = 4x$$

$$\boxed{x = \frac{R}{4}}$$

Gravitational potential at point P

$$= -\frac{Gm}{x} - \frac{G(9m)}{(R-x)}$$

$$= -Gm \left[\frac{1}{\frac{R}{4}} + \frac{9}{\frac{R}{4}} \right]$$

$$= -Gm \left[\frac{1}{\frac{R}{4}} + \frac{36}{\frac{R}{4}} \right]$$

$$= -\frac{Gm}{R} \left[4 + \frac{36}{3} \right]$$

$$= -\frac{Gm}{R} [4+12]$$

$$= -\frac{16Gm}{R}$$

Question 24: The venturi-meter works on:

Options:

- (a) Huygens's principle
- (b) Bernoulli's principle
- (c) The principle of parallel axes
- (d) The principle of perpendicular axes

Answer: (b)

Solution: (Direct theory question)

Venturi meter works on Bernoulli's principle

Question 25: The half life of a radioactive substance is 20 minutes. In how much time, the activity of substance drops to $\left(\frac{1}{16}\right)^{th}$ of its initial value?

Options:

- (a) 20 minutes
- (b) 40 minutes
- (c) 60 minutes
- (d) 80 minutes

Answer: (d)

Solution: Given

$$T_{1/2} = 20 \text{ min } (T)$$

$$\frac{N}{N_0} = \frac{1}{16}$$

We know

$$\frac{N}{N_0} = \left(\frac{1}{2}\right)^n = \frac{1}{16} \Rightarrow \left(\frac{1}{2}\right)^n = \left(\frac{1}{2}\right)^4$$

Where n is no. of half lines So $n=4$

Now, time $t = nT = 4 \times 20 = 80 \text{ min}$

Question 26: A football player is moving southward and suddenly turns eastward with the same speed to avoid an opponent. The force that acts on the player while turning as:

Options:

- (a) Along Eastward
- (b) Along Northward
- (c) Along North-East
- (d) Along South-West

Answer: (c)

Solution: Change in momentum direction will give direction of force.

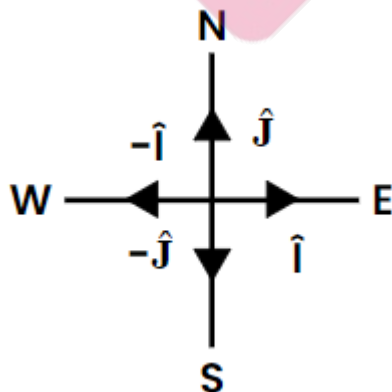

As first player moves towards south

So, direction $-\hat{j}$

$$\vec{p}_i = -p_i \hat{j}$$

Secondly turns towards East

So, direction $(+\hat{i})$

$$\vec{p}_f + p_f(\hat{i})$$

$$\Delta\vec{p} = \vec{p}_f - \vec{p}_i = p_f(\hat{i}) - (-p_i\hat{j})$$

$$= p_f\hat{i} + p_i\hat{j}$$

$$= p\hat{i} + p\hat{j}$$

$$= p(\hat{i} + \hat{j})$$

This is North East Direction

Also, force direction while turning

As the turns with same speed $|\vec{p}_f| = |\vec{p}_i| = p$

Question 27: The errors in the measurement which arise due to unpredictable fluctuations in temperature and voltage supply are:

Options:

- (a) Instrumental errors
- (b) Personal errors
- (c) Least count errors
- (d) Random errors

Answer: (d)

Solution: Direct theorem question

The errors in measurement which rise due to unpredictable fluctuations in temperature and voltage supply are random errors.

Question 28: The angular acceleration of a body, moving along the circumference of a circle, is:

Options:

- (a) Along the radius, away from centre
- (b) Along the radius towards the centre
- (c) Along the tangent to its position
- (d) Along the axis of rotation

Answer: (d)

Solution: Direct theory question

Angular acceleration of a body moving along the circumference of a circle is along the axis of rotation.

Question 29: A full wave rectifier circuit consists of two p-n junction diodes, a centre-tapped transformer, capacitor and a load resistance. Which of these components remove the ac ripple from the rectified output?

Options:

- (a) A centre-tapped transformer
- (b) p-n junction diodes
- (c) Capacitor
- (d) Load resistance

Answer: (c)

Solution: Direct theory question

Capacitor is used to remove the ac ripple from rectified output.

Question 30: The ratio of radius of gyration of a solid sphere of mass M and radius R about its own axis to the radius of gyration of the thin hollow sphere of same mass and radius about its axis is:

Options:

- (a) 3 : 5
- (b) 5 : 3
- (c) 2 : 5
- (d) 5 : 2

Answer: None of the options are correct

Solution:

None of the options matching

For solid sphere $I_1 = \frac{2}{5} MR^2$ So, $R_1^2 = \frac{2}{5} R^2$

$$\{\therefore I = MR^2\}$$

R = Radius of gyration

For hollow sphere $I_2 = \frac{2}{3} MR^2$ So, $R_2^2 = \frac{2}{3} R^2$

$$\frac{R_1^2}{R_2^2} = \frac{2}{5} R^2 \times \frac{3}{2R^2}$$

$$= \frac{3}{5}$$

$R_1 = \sqrt{3}$
$R_2 = \sqrt{5}$

Question 31: The magnitude and direction of the current in the following circuit is

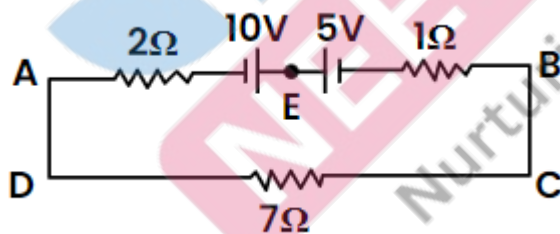

Options:

- (a) 0.2 A from B to A through E
- (b) 0.5 A from A to B through E
- (c) $\frac{5}{9}$ A from A to B through E
- (d) 1.5 A from B to A through E

Answer: (b)

Solution: Magnitude and direction of current

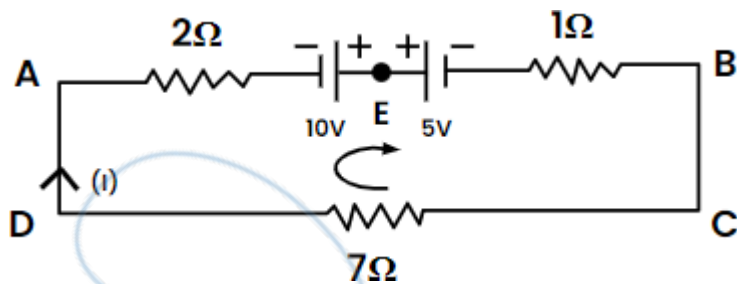

Applying KVL

Let's take current is moving clock wise

$$-2I - 7I - I + 10 - 5 = 0$$

$$-10I + 5 = 0$$

$$+10I = +5$$

$$I = \frac{1}{2} = 0.5A$$

$F (+ve)$ so from $A \rightarrow B$ through 'E'.

Question 32: An ac source is connected to a capacitor C. Due to decrease in its operating frequency:

Options:

- (a) Capacitive reactance decreases
- (b) Displacement current increases
- (c) Displacement current decreases
- (d) Capacitive reactance remains constant

Answer: (c)

Solution: $I = \frac{E}{X_c}$

$$I = \frac{E}{\frac{1}{\omega C}} = E \cdot \omega C$$

$$I = E \cdot 2\pi f \cdot C$$

So, if frequency decreases then displacement current decreases.

So, as conduction current decreases \rightarrow Displacement current also decreases.

Question 33: The net magnetic flux through any closed surface is:

Options:

- (a) Zero
- (b) Positive
- (c) Infinity
- (d) Negative

Answer: (a)

Solution: Magnetic flux through a closed surface is zero

As no. of lines entering should be equal to the no. of lines leaving

$$\int B \cdot dA = 0$$

Question 34: In a plane electromagnetic wave travelling in free space, the electric field component oscillates sinusoidally at a frequency of $2.0 \times 10^{10} \text{ Hz}$ and amplitude 48 Vm^{-1} . Then the amplitude of oscillating magnetic field is: (Speed of light in free space $= 3 \times 10^8 \text{ ms}^{-1}$)

Options:

- (a) $1.6 \times 10^{-9} T$
- (b) $1.6 \times 10^{-8} T$
- (c) $1.6 \times 10^{-7} T$
- (d) $1.6 \times 10^{-6} T$

Answer: (c)**Solution:** $E_o = 48v / m$

$$E_o = B_o C$$

$$\frac{48}{3 \times 10^8} = B_o$$

$$B_o = 16 \times 10^{-8} \\ = 1.6 \times 10^{-7} T$$

Question 35: The potential energy of along spring when stretched by 2 cm is U. if the spring is stretched by 8 cm, potential energy stored in it will be:

Options:

- (a) 2U
- (b) 4U
- (c) 8U
- (d) 16U

Answer: (d)**Solution:** Potential energy stored in spring $= \frac{1}{2} kx^2$

$$\frac{U_1}{U_2} = \frac{\frac{1}{2} kx_1^2}{\frac{1}{2} kx_2^2}$$

$$U_1 = \frac{x_1^2}{x_2^2} U_2$$

$$U_1 = \frac{(2)^2}{(8)^2} U_2$$

$$U_2 = \frac{64 \times U}{1} = 16U$$

Question 36: A bullet from a gun is fired on a rectangular wooden block with velocity u. When bullet travels 24 cm through the block along its length horizontally, velocity of bullet becomes $\frac{u}{3}$. Then it further penetrates into the block in the same direction before coming to rest exactly

at the other end of the block. The total length of the block is:

Options:

- (a) 27 cm
- (b) 24 cm
- (c) 28 cm
- (d) 30 cm

Answer: (a)

Solution: Condition 1: $v_f = \frac{u}{3}$

$$S = (24)$$

$$v_i = u$$

Using $v^2 = u^2 + 2as$

$$\left(\frac{u}{3}\right)^2 = (u)^2 + 2as$$

$$\frac{u^2}{9} = u^2 + 2 \cdot a \cdot 24$$

$$-\frac{8u^2}{9} = 48 \cdot a$$

$$a = -\frac{u^2}{54}$$

Condition 2:

$$v_f = 0$$

$$u_i = \frac{4}{3}$$

$$(0)^2 = \left(\frac{4}{3}\right)^2 + 2\left(-\frac{u^2}{54}\right) \times s$$

$$-\frac{u^2}{54} = -2 \frac{u^2}{54} \times s$$

$$s = 3m$$

So total length $24 + 3 = 27m$

Question 37: A satellite is orbiting just above the surface of the earth with period T . If d is the density of the earth and G is the universal constant of gravitation, the quantity $\frac{3\pi}{Gd}$ represents:

Options:

(a) T

(b) T^2

(c) T^3

(d) \sqrt{T}

Answer: (b)

Solution: Time period of satellite

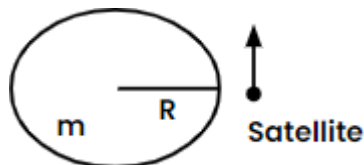

$$T = 2\pi \sqrt{\frac{R^3}{GM}}$$

Density = d

Mass = density \times volume

$$= d \times \frac{4}{3} \pi R^3$$

$$T = 2\pi \sqrt{\frac{R^3}{G.d \times \frac{4}{3} \pi R^3}}$$

$$T = 2\pi \sqrt{\frac{3}{4\pi Gd}}$$

$$T^2 = 4\pi^2 \cdot \frac{3}{4\pi Gd}$$

$$T^2 = \frac{3\pi}{Gd}$$

Question 38: The radius of inner most orbit of hydrogen atom is $5.3 \times 10^{-11} m$. What is the radius of third allowed orbit of hydrogen atom?

Options:

- (a) 0.53 \AA
- (b) 1.06 \AA
- (c) 1.59 \AA
- (d) 4.77 \AA

Answer: (d)

Solution: $n = 3, n = 1, r_1 = 5.3 \times 10^{-11}$

$$r_n = r_1 n^2$$

$$r = r_1 (3)^2$$

$$= 5.3 \times 10^{-11} \times 9$$

$$= 4.77 \times 10^{-10}$$

Question 39: The net impedance of circuit (as shown in figure) will be

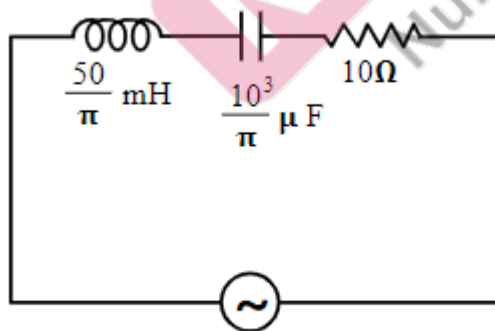

Options:

- (a) $10\sqrt{2} \Omega$
- (b) 15Ω
- (c) $5\sqrt{5} \Omega$
- (d) 15Ω

Answer: (c)

Solution: $X_L = 2\pi \times 50 \times \frac{50}{\pi} \times 10^{-3}$

$$X_L = 5000 \times 10^{-3} = 5\Omega$$

$$X_C = \frac{1}{100\pi \times \frac{1000}{\pi} \times 10^{-6}}$$

$$(X_C = 10\Omega)$$

$$R = 10\Omega$$

$$Z = \sqrt{(X_C - X_L)^2 + R^2}$$

$$= \sqrt{(10 - 5)^2 + 10^2}$$

$$= \sqrt{25 + 100} = 5\sqrt{5}$$

Question 40: The x-t graph of a particle performing simple harmonic motion is shown in the figure. The acceleration of the particle at $t = 2$ s is:

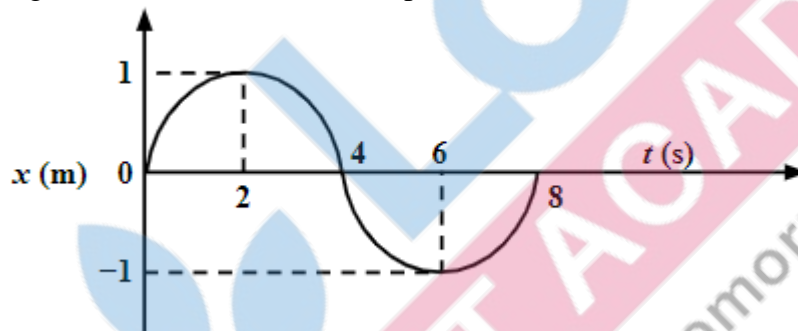

Options:

- (a) $\frac{\pi^2}{8} \text{ms}^{-2}$
(b) $-\frac{\pi^2}{8} \text{ms}^{-2}$
(c) $\frac{\pi^2}{16} \text{ms}^{-2}$
(d) $-\frac{\pi^2}{16} \text{ms}^{-2}$

Answer: (d)

Solution: $x = A \sin(\omega t + \phi)$

$$t = 0, x = 0, \phi = 0$$

$$x = A \sin \omega t$$

$$T = \frac{2\pi}{\omega}$$

$$\frac{2\pi}{\omega} = 8 \left(\omega = \frac{\pi}{4} \right)$$

$$x = \sin \omega t \text{ as } (A = 1)$$

$$\frac{dx}{dt} = (\cos \omega t) \cdot \omega$$

$$\frac{d^2x}{dt^2} = -\omega^2 \sin \omega t$$

$$a = -\frac{\pi^2}{16} \sin\left(\frac{\pi}{4} k \times 2\right) \text{ at } t = 2$$

$$a = -\frac{\pi^2}{16} \sin\left(\frac{\pi}{2}\right)$$

$$= -\frac{\pi^2}{16}$$

Question 41: In the figure shown here, what is the equivalent focal length of the combination of lenses (Assume that all layers are thin)?

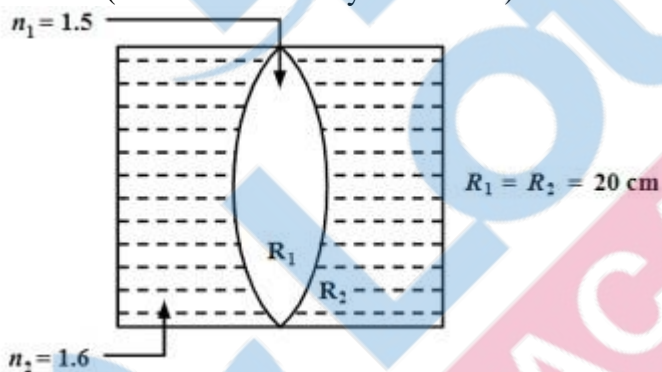

Options:

- (a) 40 cm
- (b) -40 cm
- (c) -100 cm
- (d) -50 cm

Answer: (c)

Solution:

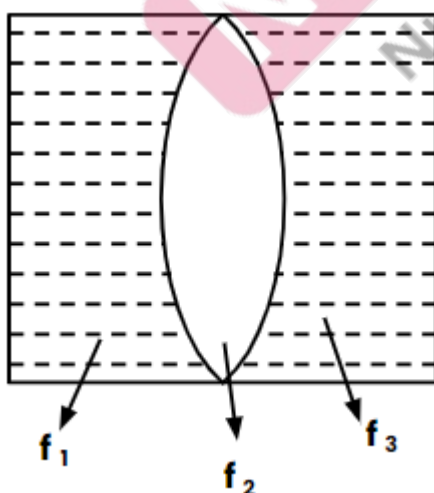

$$\frac{1}{f} = \left(\frac{\mu^R}{s} - 1\right) \left(\frac{1}{R_1} - \frac{1}{R_2}\right)$$

$$\frac{f}{1} = \left(\frac{1.6}{1} - 1 \right) \left(\frac{10}{1} - \frac{20}{1} \right)$$

$$\frac{1}{f_1} = 0.6 \left(\frac{-1}{20} \right)$$

$$\frac{1}{f_1} = \frac{-0.3}{10}$$

Since left side lense & right side lense are same

$$\frac{1}{f_3} = \frac{1}{f_1} = \frac{0.3}{10}$$

$$\frac{f}{2} = \left(\frac{1.5}{1} - 1 \right) \left(\frac{20}{1} - \frac{-20}{1} \right)$$

$$\frac{1}{f_2} = 0.5 \left(\frac{2}{20} \right)$$

$$\frac{1}{f_2} = \frac{0.5}{10}$$

$$\frac{1}{F} = \frac{1}{f_1} + \frac{1}{f_2} + \frac{1}{f_3}$$

$$= \frac{-0.3}{10} + \frac{0.5}{10} + \frac{(-0.3)}{10}$$

$$= \frac{-0.6 + 0.5}{10}$$

$$= \frac{-0.1}{10}$$

$$\frac{1}{F} = \frac{-1}{100}$$

$$F = -100 \text{ cm}$$

Question 42: An electric dipole is placed as shown in the figure,

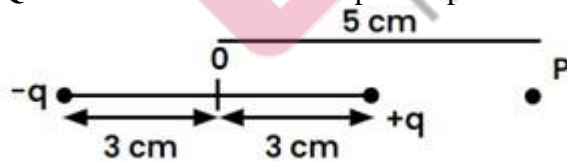

The electric potential (in 10^2 V) at point P due to the dipole is ($\epsilon_0 \approx$ permittivity of free space

and $\frac{1}{4\pi\epsilon_0} = K$):

Options:

(a) $\left(\frac{3}{8} \right) qK$

(b) $\left(\frac{5}{8} \right) qK$

$$(c) \left(\frac{8}{5}\right)qK$$

$$(d) \left(\frac{8}{3}\right)qK$$

Answer: (a)

Solution:

$$V_D = V_q + V_{-q}$$

$$= \frac{Kq}{(5-3) \times 10^{-2}} + \frac{K(-q)}{(5+3) \times 10^{-2}}$$

$$= \frac{Kq}{10^{-2}} \left[\frac{1}{2} - \frac{1}{8} \right]$$

$$= Kq \times 10^2 \left[\frac{4}{8} - \frac{1}{8} \right]$$

$$= Kq \left[\frac{3}{8} \right] \times 10^2$$

$$= Kq \left[\frac{6}{16} \right] \times 10^2$$

$$= Kq \left[\frac{3}{8} \right] \times 10^2$$

$$V_D = Kq \left[\frac{3}{8} \right] \times 10^2$$

Question 43: A horizontal bridge is built across a river. A student standing on the bridge throws a small ball vertically upwards with a velocity 4 m s^{-1} . The ball strikes the water surface after 4 s. The height of bridge above water surface is (Take $g = 10 \text{ m s}^{-2}$):

Options:

(a) 56 m

(b) 60 m

(c) 64 m

(d) 68 m

Answer: (c)

Solution:

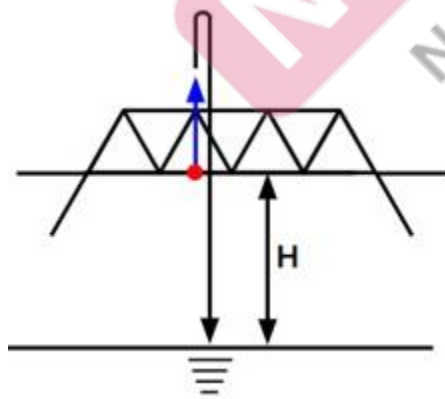

$$u = 4 \text{ m/s}$$

$$a = -10 \text{ m/s}^2$$

$$S = -H$$

$$t = 6$$

$$S = ut + \frac{1}{2}at^2$$

$$-H = 4(4) + \frac{1}{2}(-10)(4)^2$$

$$-H = 16 - 5 \times 16$$

$$-H = 16(1-5)$$

$$H = 64 \text{ m}$$

Question 44: Calculate the maximum acceleration of a moving car so that a body lying on the floor of the car remains stationary. The coefficient of static friction between the body and the floor is ($g = 10 \text{ m s}^{-2}$)

Options:

- (a) 1.2 m s^{-2}
- (b) 150 m s^{-2}
- (c) 1.5 m s^{-2}
- (d) 50 m s^{-2}

Answer: (c)

Solution:

Observing body from car i.e., non inertial frame of reference

From this frame, body is in equilibrium

$$N = mg \quad \dots(1)$$

$$ma = f_c$$

$$ma = \mu_s N$$

$$ma = \mu_s (mg) \text{ from } a = \mu_s g$$

$$a = 0.15 \times 10$$

$$a = 1.5 \text{ m / s}^2$$

Pseudo force

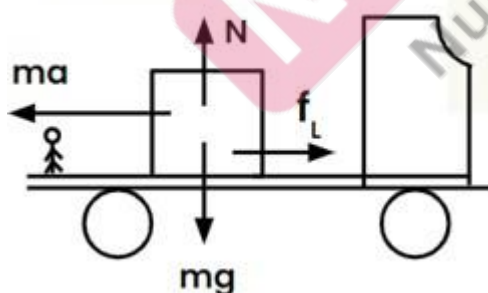

Question 45: 10 resistors, each of resistance R are connected in series to a battery of emf E and negligible internal resistance. Then those are connected in parallel to the same battery, the current is increased n times. The value of n is:

Options:

- (a) 10
- (b) 100
- (c) 1

(d) 1000

Answer: (b)

Solution:

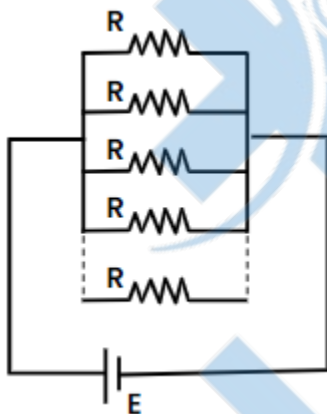
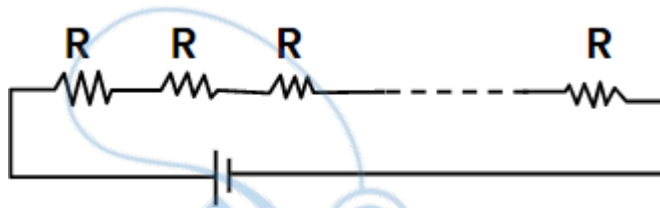

$$R_{eq} = nR = 10 \times R$$

$$I = \frac{E}{R_{eq} + r} = \frac{E}{10R}$$

$$R_{eq} = \frac{R}{n} = \frac{R}{100}$$

$$I = \frac{E}{R_{eq} + r} = \frac{E}{\frac{R}{10}}$$

$$I_2 = \frac{10E}{R}$$

Now

$$\frac{I_2}{I_1} = \frac{\frac{10E}{R}}{\frac{E}{10R}} = 100$$

$$I_2 = 100I_1$$

$$n = 100$$

Question 46: For the following logic circuit, the truth table is:

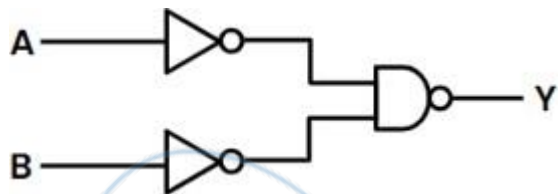

Options:

- | | | | |
|-----|---|---|---|
| | A | B | Y |
| | 0 | 0 | 1 |
| (a) | 0 | 1 | 1 |
| | 1 | 0 | 1 |
| | 1 | 1 | 0 |
| | A | B | Y |
| | 0 | 0 | 0 |
| (b) | 0 | 1 | 1 |
| | 1 | 0 | 1 |
| | 1 | 1 | 1 |
| | A | B | Y |
| | 0 | 0 | 1 |
| (c) | 0 | 1 | 0 |
| | 1 | 0 | 1 |
| | 1 | 1 | 0 |
| | A | B | Y |
| | 0 | 0 | 0 |
| (d) | 0 | 1 | 1 |
| | 1 | 0 | 1 |
| | 1 | 1 | 1 |

Answer: (b)

Solution:

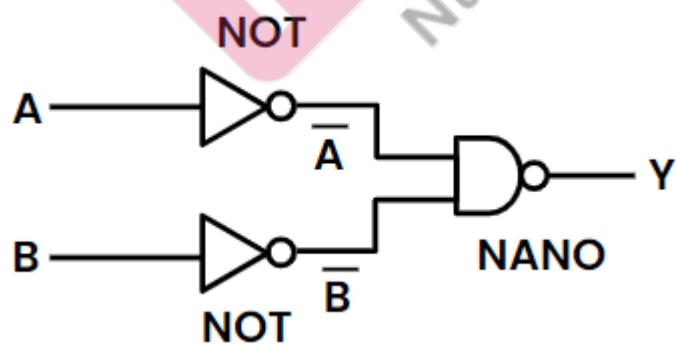

$$Y = \overline{\overline{A}} \cdot \overline{\overline{B}}$$

$$Y = \overline{\overline{A}} + \overline{\overline{B}}$$

$$Y = A + B$$

It is effectively OR gate

∴ Truth table

A	B	A + B
0	0	0
0	1	1
1	0	1
1	1	1

Question 47: A very long conducting wire is bent in a semi-circular shape from A to B as shown in figure. The magnetic field at point P for steady current configuration is given by:

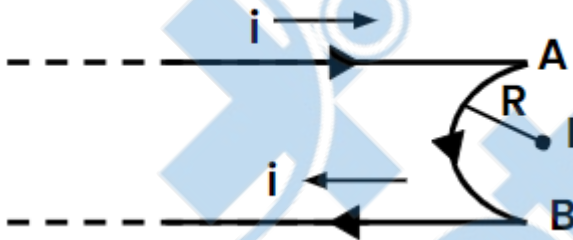

Options:

- (a) $\frac{\mu_0 i}{4R}$ pointed into the page
- (b) $\frac{\mu_0 i}{4R}$ pointed away from the page
- (c) $\frac{\mu_0 i}{4R} \left[\frac{1}{2} - \frac{\pi}{2} \right]$ pointed away from the page
- (d) $\frac{\mu_0 i}{4R} \left[\frac{1}{2} - \frac{\pi}{2} \right]$ pointed into the page

Answer: (c)

Solution:

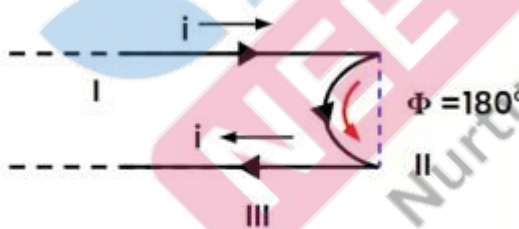

Outward (+)
Inward (-)

As per sign convention magnetic field by all three parts at point P

Hence net electric field,

$$\vec{B} = \vec{B}_I + \vec{B}_{II} + \vec{B}_{III}$$

$$\vec{B} = -B_I + B_{II} - B_{III}$$

$$B = \frac{-\mu_0 I}{4\pi r} + \frac{\mu_0 I}{4\pi r} (\pi) - \frac{\mu_0 I}{4\pi r}$$

$$B = \frac{\mu_0 I}{4\pi r} \left[-1 + \pi - 1 \right]$$

$$B = \frac{\mu_0 I}{4\pi r} \left[\pi - 2 \right]$$

$$B = \frac{\mu_0 I}{4r} \left[\frac{2}{\pi} \right]$$

As this answer is positive outward

Question 48: The resistance of platinum wire at 0°C is 2Ω and 6.8Ω at 80°C . The temperature coefficient of resistance of the wire is:

Options:

- (a) $3 \times 10^{-4} \text{ }^\circ\text{C}^{-1}$
- (b) $3 \times 10^{-3} \text{ }^\circ\text{C}^{-1}$
- (c) $3 \times 10^{-2} \text{ }^\circ\text{C}^{-1}$
- (d) $3 \times 10^{-1} \text{ }^\circ\text{C}^{-1}$

Answer: (c)

Solution:

$$R_0 = 2\Omega \rightarrow T_0 = 0^\circ\text{C}$$

$$R = 6.8\Omega \rightarrow T = 80^\circ\text{C}$$

$$R = R_0 (1 + \alpha \Delta T)$$

$$R - R_0 = R_0 \alpha \Delta T$$

$$\alpha = \frac{R - R_0}{R_0 \Delta T}$$

$$\alpha = \frac{6.8 - 2}{2 \times 80}$$

$$\alpha = \frac{4.8}{160}$$

$$\alpha = \frac{48}{16 \times 100}$$

$$\alpha = 3 \times 10^{-2} \text{ }^\circ\text{C}^{-1}$$

Question 49: A wire carrying a current I along the positive x -axis has length L . It is kept in a magnetic field $\vec{B} = (2\hat{i} + 3\hat{j} - 4\hat{k})\text{T}$. The magnitude of the magnetic force acting on the wire is:

Options:

- (a) $3IL$
- (b) $\sqrt{5} IL$
- (c) $5IL$
- (d) $\sqrt{3} IL$

Answer: (c)

Solution:

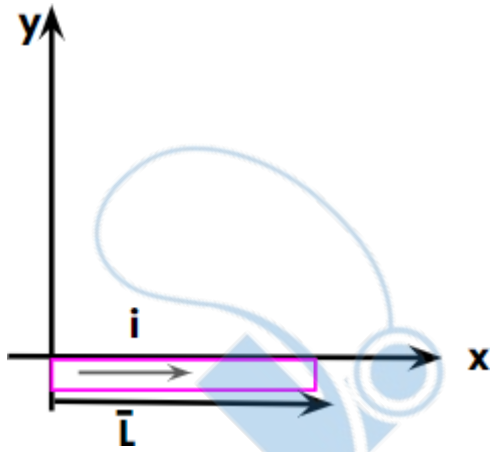

$$\vec{L} = L\hat{i}$$

Force on conductor due to external magnetic field

$$\vec{F} = I(\vec{L} \times \vec{B})$$

$$\vec{F} = I[L\hat{i} \times (2\hat{i} + 3\hat{j} - 4\hat{k})]$$

$$\vec{F} = I[2L \times 0 + 3L(\hat{i} \times \hat{j}) - 4L(\hat{i} \times \hat{k})]$$

$$\vec{F} = I[36\hat{k} - 4L(-\hat{j})]$$

$$\vec{F} = IL[4\hat{j} + 3\hat{k}]$$

$$|\vec{F}| = IL\sqrt{4^2 + 3^2}$$

$$F = 5IL$$

Question 50: Two thin lenses are of same focal lengths (f), but one is convex and the other one is concave. When they are placed in contact with each other, the equivalent focal length of the combination will be:

Options:

(a) Zero

(b) $\frac{f}{4}$

(c) $\frac{f}{2}$

(d) Infinite

Answer: (d)

Solution:

For equivalent focal length

$$\frac{1}{F} = \frac{1}{f_1} + \frac{1}{f_2}$$

$$\frac{1}{F} = \frac{1}{f} + \frac{1}{(-f)}$$

$$\frac{1}{F} = 0$$

$$F = \frac{1}{0}$$

$$F = \infty$$



Question 51: Select the correct statements from the following:

- A. Atoms of all elements are composed of two fundamental particles.
- B. The mass of the electron is 9.10939×10^{-31} kg.
- C. All the isotopes of a given element show same chemical properties
- D. Protons and electrons are, collectively known as nucleons.
- E. Dalton's atomic theory, regarded the atom as an ultimate particle of matter.

Choose the correct answer from the options given below.

Options:

- (a) A, B and C only
- (b) C, D and E only
- (c) A and E only
- (d) B, C and E only

Answer: (d)

Solution: Answer is option 4

A: Atoms of all elements are composed of 3 fundamental particles i.e. e^- , p^+ and nu.

B: Mass of e^- is 9.10939×10^{-31} kg

C: All isotope of a given element shown same chemical properties as they have same no. of valence e^- .

D: Nucleons = $P^+ + nu$

E: Dalton's atomic theory, regarded the atom as an ultimate particle of matter.

Question 52: Given below are two statements: one is labelled as Assertion A and the other is labelled as Reason R:

Assertion A: A reaction can have zero activation energy.

Reasons R: The minimum extra amount of energy absorbed by reactant molecules so that their energy becomes equal to threshold value, is called activation energy.

In the light of the above statements, choose the correct answer from the options given below : CO

Options:

- (a) Both A and R are true and R is the correct explanation of A
- (b) Both A and R are true and R is not the correct explanation of A
- (c) A is true but R is false.
- (d) A is false but R is true.

Answer: (b)

Solution: A reaction can have $E_a = 0$

The minimum extra amount of energy absorbed by reactant molecules so that their energy becomes equal to threshold values is called activation energy.

Both A & R are true but R is not the correct explanation of A

Question 53: A compound is formed by two elements A and B. The element B forms cubic close packed structure and atoms of A occupy $1/3$ of tetrahedral voids. If the formula of the compound is A_xB_y , then the value of $x + y$ is in option

Options:

- (a) 5
- (b) 4
- (c) 3

(d) 2

Answer: (a)

Solution:

Effective number of atoms

Contribution of B = 4, Tetrahedral voids = 8

Contribution of A $\rightarrow \frac{1}{3}$ T.TH void $\frac{8}{3}$

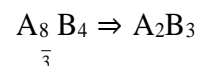

$$x + y = 5$$

Question 54: Given below are two statements: one is labelled as Assertion A and the other is labelled as Reason R

Assertion A: Metallic sodium dissolves in liquid ammonia giving a deep blue solution. which is paramagnetic.

Reasons R: The deep blue solution is due to the formation of amide.

In the light of the above statements, choose the correct answer from the options given below:

Options:

- (a) Both A and R are true and R is the correct explanation of A.
- (b) Both A and R are true but R is NOT the correct explanation of A.
- (c) A is true but R. is false.
- (d) A is false but R is true.

Answer: (c)

Solution: Metallic Na dissolves in liquid NH_3 giving a deep blue solution, which is paramagnetic



Assertions true

The deep blue colour is because of ammoniate electrons. So, reason is false.

Question 55: Amongst the following, the total number of species NOT having eight electrons around central atom in its outer most shell, is

NH_3 , AlCl_3 , BeCl_2 , CCl_4 , PCl_5

Options:

- (a) 3
- (b) 2
- (c) 4
- (d) 1

Answer: (a)

Solution: AlCl_3 and $\text{BeCl}_2 \Rightarrow$ Hypovalent

$\text{PCl}_5 \Rightarrow$ Hypervalent

Question 56: Which amongst the following molecules on polymerization produces neoprene?

Options:

- (a) $\text{H}_2\text{C} = \text{CH}-\text{CH} = \text{CH}_2$
- (b)

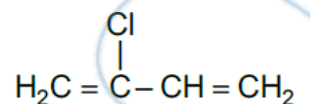

(d)

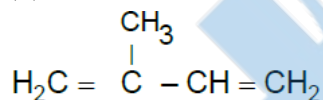

Answer: (b)

Solution:

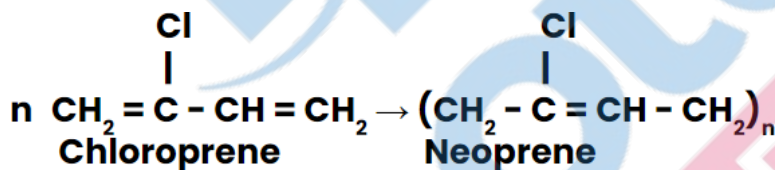

Question 57: In Lassaigne's extract of an organic compound, both nitrogen and sulphur are present, which gives blood red colour with Fe^{3+} due to the formation of

Options:

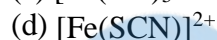

Answer: (d)

Solution: SCN^- reacts with Fe^{3+} to form the complex $[\text{Fe}(\text{SCN})]^{2+}$
 Real Blood Color [Test for both S and N]

Question 58: Weight (g) of two moles of the organic compound, which is obtained by heating sodium ethanoate with sodium hydroxide in presence of calcium oxide is :

Options:

(a) 16

(b) 32

(c) 30

(d) 18

Answer: (b)

Solution:

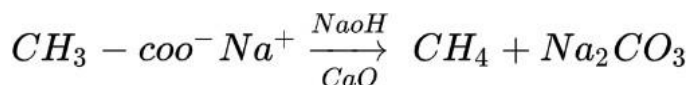

[Decarboxylation]

Product: CH_4

Molecular mass: 16
2 mol of CH₄ → 32 g

Question 59: Some tranquilizers are listed below. Which one from the following belongs to barbiturates?

Options:

- (a) Chlordiazepoxide
- (b) Meprobamate
- (c) Valium
- (d) Veronal

Answer: (d)

Solution: Barbiturates are hypnotic (Sleep producing)

Eg:- Veronal, Amytal, Nembutal, etc

Question 60: The conductivity of centimolar solution of KCl at 25°C is 0.0210 ohm⁻¹ cm⁻¹ and the resistance of the cell containing the solution at 25°C is 60 ohm. The value of cell constant is

Options:

- (a) 1.34 cm⁻¹
- (b) 3.28 cm⁻¹
- (c) 1.26 cm⁻¹
- (d) 3.34 cm⁻¹

Answer: (c)

Solution: Cell Constant $G^* = \text{Specific Conductance} \times R$ given

$R = 60$ ohms

$K = 0.0210 \text{ ohm}^{-1}\text{cm}^{-1}$

$G^* = 0.0210 \times 60$

$= 1.26 \text{ cm}^{-1}$

Question 61: Complete the following reaction

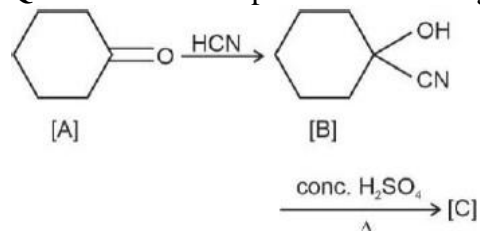

C is _____

Options:

- (a)

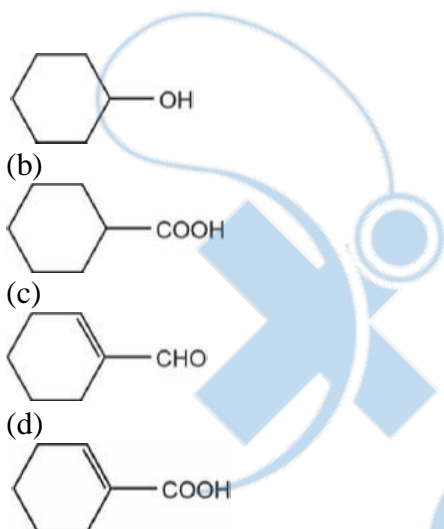

Answer: (d)

Solution:

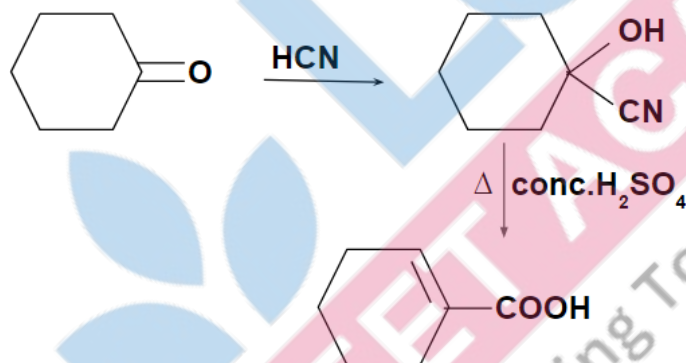

Question 62: Homoleptic complex from the following complexes is

Options:

- (a) Potassium trioxalatoaluminate (III)
- (b) Diamminechloridonitrito-N-platinum (II)
- (c) Pentaamminecarbonatocobalt (III) chloride
- (d) Triamminetriaquachromium (III) chloride

Answer: (a)

Solution: $K_3[Al(ox)_3]$

Question 63: The relation between n_m , (n_m = the number of permissible values of magnetic quantum number (m)) for a given value of azimuthal quantum number (l), is

Options:

- (a) $l = \frac{n_m - 1}{2}$
- (b) $l = 2n_m + 1$
- (c) $n_m = 2l^2 + 1$

(d) $n_m = l + 2$

Answer: (a)

Solution: $n_m = 2l + 1$

$$l = \frac{n_m - 1}{2}$$

Question 64: The stability of Cu^{2+} is more than Cu^{+} salts in aqueous solution due to

Options:

- (a) First ionisation enthalpy
- (b) Enthalpy of atomization
- (c) Hydration energy
- (d) Second ionisation enthalpy

Answer: (c)

Solution: Hydration energy a charge $\propto \frac{1}{\text{size}}$

Question 65: Taking stability as the factor, which one of the following represents correct relationship?

Options:

- (a) $\text{TlCl}_3 > \text{TlCl}$
- (b) $\text{InI}_3 > \text{InI}$
- (c) $\text{AlCl} > \text{AlCl}_3$
- (d) $\text{TlI} > \text{TlI}_3$

Answer: (d)

Solution: Inert pair effect.

Question 66: Which one is an example of heterogenous catalysis?

Options:

- (a) Oxidation of sulphur dioxide into sulphur trioxide in the presence of oxides of nitrogen
- (b) Hydrolysis of sugar catalysed by H^+ ions
- (c) Decomposition of ozone in presence of nitrogen monoxide
- (d) Combination between dinitrogen and dihydrogen to form ammonia in the presence of finely divided iron

Answer: (d)

Solution:

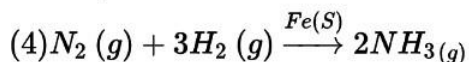
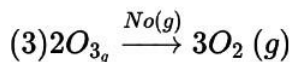
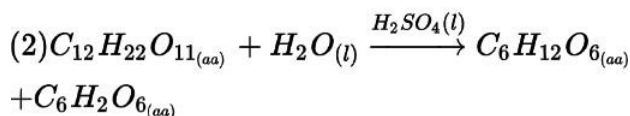
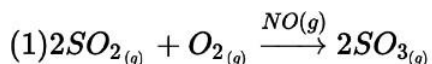

Reactants and catalyst are in different phases.

Question 67: The number of σ bonds, π bonds and lone pair of electrons in pyridine, respectively are:

Options:

- (a) 11, 2, 0
- (b) 12, 3, 0
- (c) 11, 3, 1
- (d) 12, 2, 1

Answer: (c)

Solution:

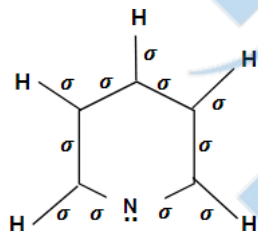

In the given structures, 1 lone pair

σ bonds : 11

π bonds : 3

Lone pair : 1

Question 68: The correct order of energies of molecular orbitals of N_2 molecule, is

Options:

- (a) $\sigma 1s < \sigma^* 1s < \sigma 2s < \sigma^* 2s < (\pi 2p_x = \pi 2p_y) < \sigma 2p_z < (\pi^* 2p_x = \pi^* 2p_y) < \sigma^* 2p_z$
- (b) $\sigma 1s < \sigma^* 1s < \sigma 2s < \sigma^* 2s < \sigma 2p_z < (\pi 2p_x = \pi 2p_y) < (\pi^* 2p_x = \pi^* 2p_y) < \pi^* 2p_z$
- (c) $\sigma 1s < \sigma^* 1s < \sigma 2s < \sigma^* 2s < \sigma 2p_z < \sigma^* 2p_z < (\pi 2p_x = \pi 2p_y) < (\pi^* 2p_x = \pi^* 2p_y)$
- (d) $\sigma 1s < \sigma^* 1s < \sigma 2s < \sigma^* 2s < (\pi 2p_x = \pi 2p_y) < (\pi^* 2p_x = \pi^* 2p_y) < \sigma 2p_z < \sigma^* 2p_z$

Answer: (a)

Solution: For the species having total electrons less than or equal to 14, the molecular electronic configuration is written as:

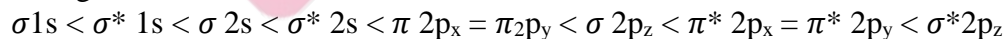

Question 69: Given below are two statements : one is labelled as Assertion A and the other is labelled as Reason R

Assertion A: Helium is used to dilute oxygen in diving apparatus.

Reason R: Helium has high solubility in O_2 .

In the light of the above statements, choose the correct answer from the options given below

Options:

- (a) Both A and R are true and R correct explanation of A
- (b) Both A and R are true and R is NOT the correct explanation of A
- (c) A is true but R is false
- (d) A is false but R is true

Answer: (b)

Solution: Both A and R are true and R is NOT the correct explanation of A

Question 70: For a certain reaction, the rate = $k[A]^2[B]$, when the initial concentration of A is tripled keeping concentration of B constant, the initial rate would

Options:

- (a) Decrease by a factor of nine
- (b) Increase by a factor of six
- (c) Increase by a factor of nine
- (d) Increase by a factor of three

Answer: (c)

Solution:

$$\therefore R = K[A]^2[B]^1$$

$$R^1 = K[3A]^2[B]^1$$

$$\frac{R^1}{R} = \frac{K9[A]^2[B]^1}{K[A]^2[B]^1}$$

$$R^1 = 9R$$

Question 71: Identify product (A) in the following reaction:

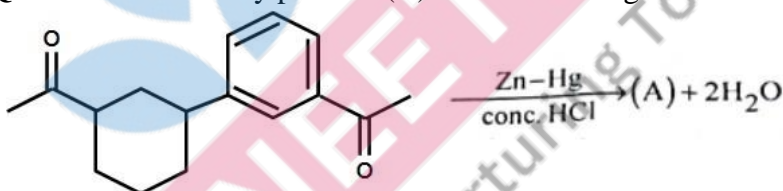

Options:

(a)

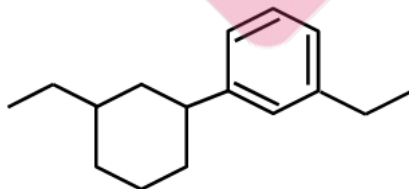

(b)

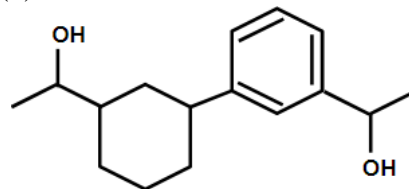

(c)

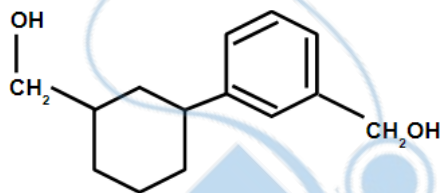

(d)

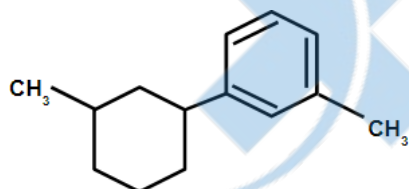

Answer: (a)

Solution:

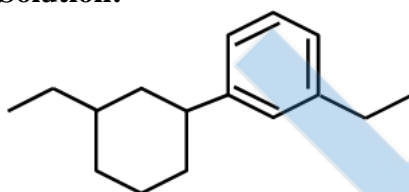

Question 72: Which of the following reactions will NOT give primary amine as the product?

Options:

(a)

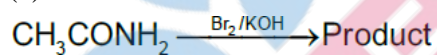

(b)

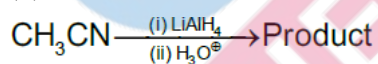

(c)

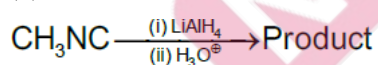

(d)

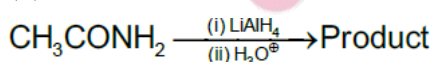

Answer: (c)

Solution: Methyl isocyanide would produce secondary amine

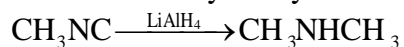

Question 73: Which amongst the following options are **correct** graphical representation of Boyle's Law?

Options:

(a)

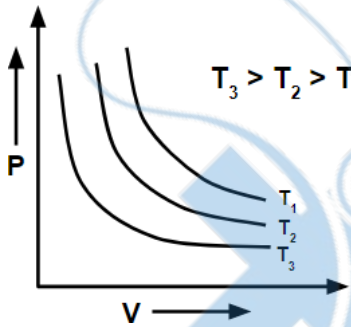

(b)

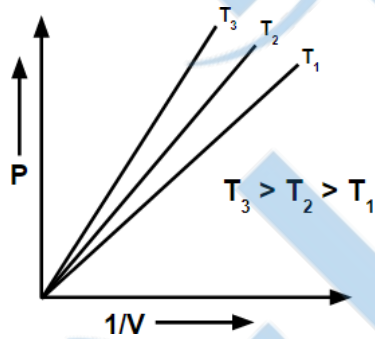

(c)

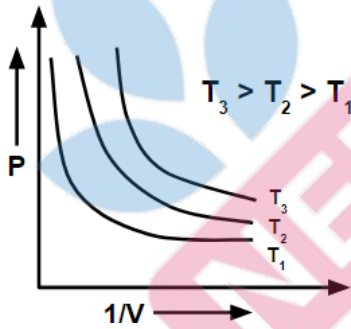

(d)

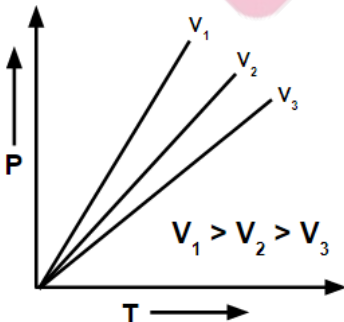

Answer: (b)

Solution:

$$pV = nRT$$

$$\underbrace{P}_Y = \underbrace{(nRT)}_m \underbrace{\frac{1}{V}}_x$$

m a T
 $T_3 > T_2 > T_1$

Question 74: Amongst the given options which of the following molecules/ ion acts as a Lewis acid?

Options:

- (a) NH_3
- (b) H_2O
- (c) BF_3
- (d) OH^-

Answer: (c)

Solution: BF_3 is hypovalent compound

Question 75: The element expected to form largest ion to achieve the nearest noble gas configuration is

Options:

- (a) O
- (b) F
- (c) N
- (d) Na

Answer: (c)

Solution:

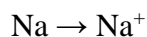
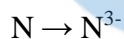
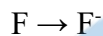
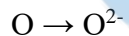

For isoelectronic species

$Z \uparrow$ size \downarrow

Question 76: The given compound

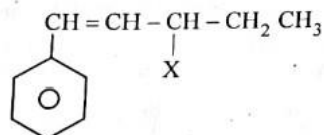

is an example of _____.

Options:

- (a) Benzylic halide
- (b) Aryl halide
- (c) Allylic halide
- (d) Vinylic halide

Answer: (c)

Solution:

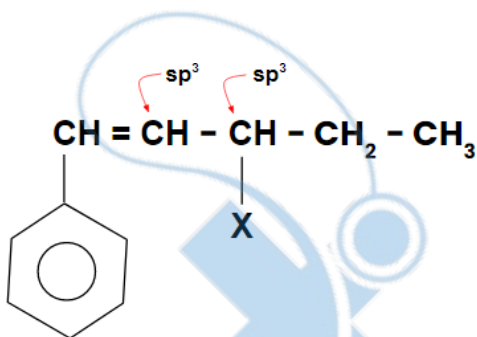

Halogen is attached to a sp^3 -C which is further bonded to sp^2 - C [Allyl system] Hence allyl halide

Question 77: Given below are two statements :

Statement I: A unit formed by the attachment of a base to 1' position of sugar is known as nucleoside.

Statement II: When nucleoside is linked to phosphorous acid at 5' -position of sugar moiety, we get nucleotide.

In the light of the above statements, choose the correct answer from the options given below :

Options:

- (a) Both Statement I and Statement II are true
- (b) Both Statement I and Statement II are false
- (c) Statement I is true but Statement II is false
- (d) Statement I is false but Statement II is true

Answer: (c)

Solution: A unit formed by the attachment of a base to 1' position of sugar is known as nucleoside

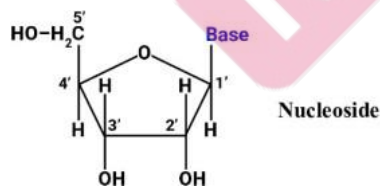

When nucleoside is linked to phosphoric acid at 5'-position of sugar moiety, we get a nucleotide.

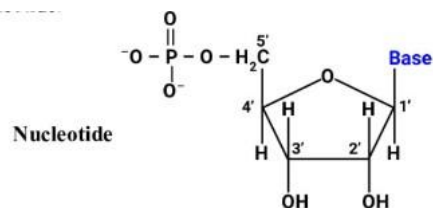

Question 78: Intermolecular forces are forces of attraction and repulsion between interacting particles that will include

- A. dipole - dipole forces

- B. dipole - induced dipole forces
- C. hydrogen bonding
- D. covalent bonding
- E. dispersion forces

Choose the most appropriate answer from the options given below :

Options:

- (a) B, C, D, E are correct
- (b) A, B, C, D are correct
- (c) A, B, C, E are correct
- (d) A, C, D, E are correct

Answer: (c)

Solution: Covalent bonding is an interatomic force (Primary force)
Remaining all are intermolecular forces

Question 79: Which of the following statements are NOT correct?

- A. Hydrogen is used to reduce heavy metal oxides to metals.
- B. Heavy water is used to study reaction mechanism.
- C. Hydrogen is used to make saturated fats from oils.
- D. The H-H bond dissociation enthalpy is lowest as compared to a single bond between two atoms of any elements.
- E. Hydrogen reduces oxides of metals that are more active than iron.

Choose the most appropriate answer from the options given below:

Options:

- (a) B, D only
- (b) D, E only
- (c) A, B, C only
- (d) B, C, D, E only

Answer: (b)

Solution: Statements D and E are wrong

→ H.H Bond dissociation enthalpy is greater than C - C bond.

→ Hydrogen reduces oxides of metals that are less active than Iron

Question 80: Which one of the following statements is correct?

Options:

- (a) The bone in human body is an inert and unchanging substance.
- (b) Mg plays roles in neuromuscular function and interneuronal transmission
- (c) The daily requirement of Mg and Ca in the human body is estimated to be 0.2-0.3 g.
- (d) All enzymes that utilise ATP in phosphate transfer require Ca as the cofactor

Answer: (c)

Solution: The daily requirement in the human body has been estimated to be 200 - 300 mg 0.2-0.3 gams.

All enzymes that utilise ATP in phosphate transfer require magnesium.

Question 81: Match List-I with List-II.

List-I	List-II
A. Coke	I. Carbon atoms are sp ³ hybridised
B. Diamond	II. Used as a dry lubricant
C. Fullerene	III. Used as a reducing agent
D. Graphite	IV. Cage like molecules

Choose the correct answer from the options given below :

Options:

- (a) A-II, B-IV, C-I, D-III
- (b) A-IV, B-I, C-II, D-III
- (c) A-III, B-I, C-IV, D-II
- (d) A-III, B-IV, C-I, D-II

Answer: (c)

Solution: A-III, B-I, C-IV, D-II

Question 82: The right option for the mass of CO₂ produced by heating 20 g of 20% pure limestone is (Atomic mass of Ca = 40) $[\text{CaCO}_3 \xrightarrow{1200\text{K}} \text{CaO} + \text{CO}_2]$

Options:

- (a) 1.76 g
- (b) 2.64 g
- (c) 1.32 g
- (d) 1.12 g

Answer: (b)

Solution: 2.64 g

Question 83: Identify the product in the following reaction:

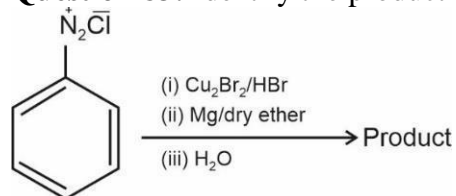

Options:

(a)

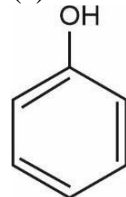

(b)

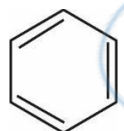

(c) MgBr

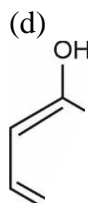

Answer: (b)

Solution:

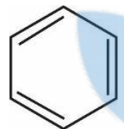

Question 84: Given below are two statements: one is labelled as Assertion A and the other is labelled as Reason R

Assertion A: In equation $\Delta_r G = -nFE_{\text{cell}}$, value of $\Delta_r G$ depends on n.

Reasons R: E_{cell} is an intensive property and $\Delta_r G$ is an extensive property.

In the light of the above statements, choose the correct answer from the options given below

Options:

- (a) Both A and R are true and R is the correct explanation of A
- (b) Both A and R are true and R is NOT the correct explanation of A
- (c) A is true but R is false
- (d) A is false but R is true

Answer: (b)

Solution: $\Delta_r G = -nFE_{\text{cell}}$

and $\Delta_r G$ depends on n

A is correct

E_{cell} is intensive property and $\Delta_r G$ is an extensive property

R is also correct

Reason is not the correct explanation for assertion

Question 85: Consider the following reaction and identify the product (P).

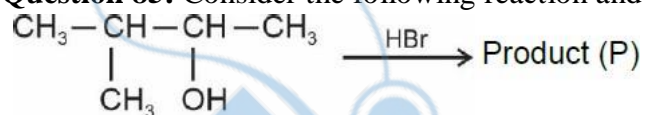

3-Methylbutan-2-ol

Options:

(a)

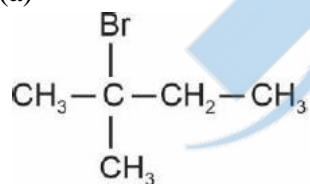

(b) $\text{CH}_3\text{CH} = \text{CH} - \text{CH}_3$

(c)

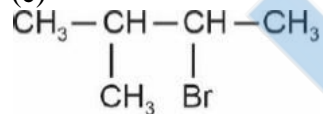

(d)

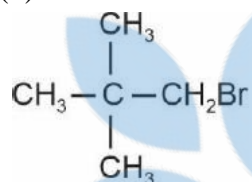

Answer: (a)

Solution:

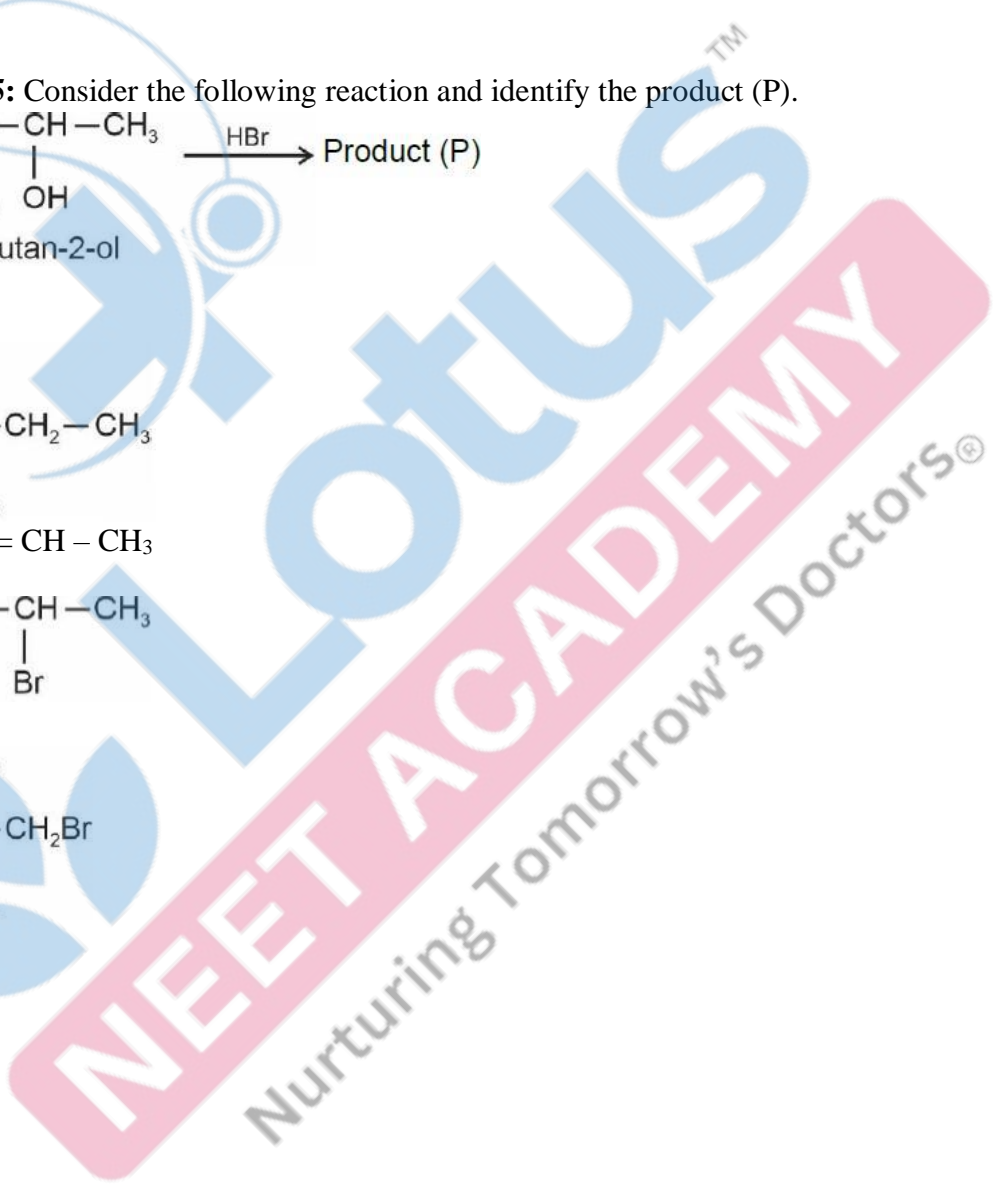

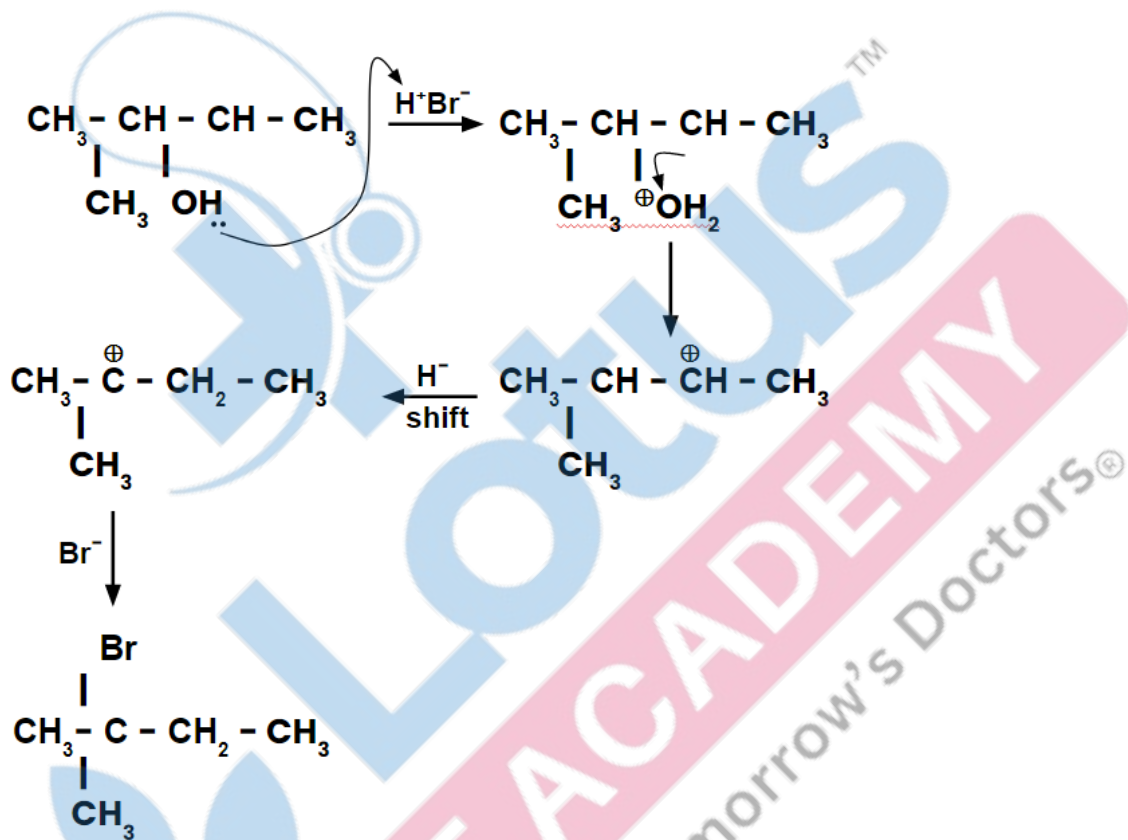

Question 86: Consider the following compounds/species:

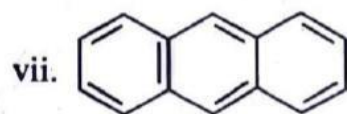

The number of compounds/species which obey Huckel's rule is _____.

Options:

- (a) 4
- (b) 6
- (c) 2

(d) 5

Answer: (a)

Solution:

(i)

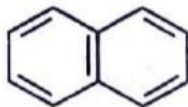

$$4n+2 = 10$$
$$n=2 \text{ (valid)}$$

(ii)

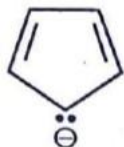

$$4n+2 = 6$$
$$n=1 \text{ (valid)}$$

(iii)



$$4n+2 \text{ (not valid)}$$

(iv)



$$4n+2 \text{ (not valid)}$$

(v)



$$4n+2 = 2$$
$$n=0 \text{ (valid)}$$

(vi)



$$4n+2 \text{ (not valid)}$$

(vii)

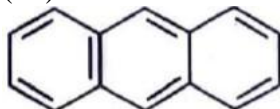

$$4n+2 = 14$$
$$n=3 \text{ (valid)}$$

Question 87: Identify the major product obtained in the following reaction

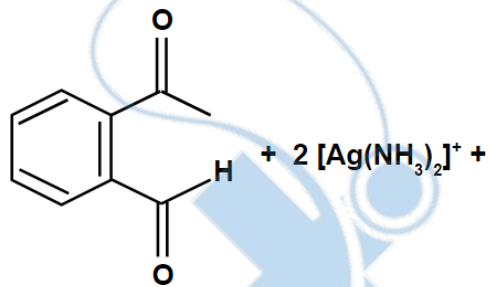

3-OH $\xrightarrow{\Delta}$ major product

Options:

(a)

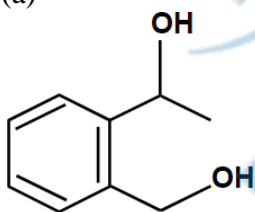

(b)

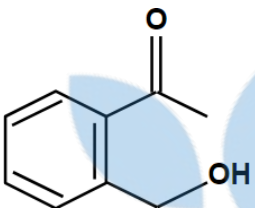

(c)

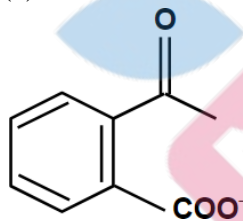

(d)

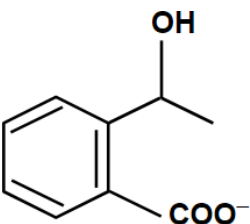

Answer: (c)

Solution:

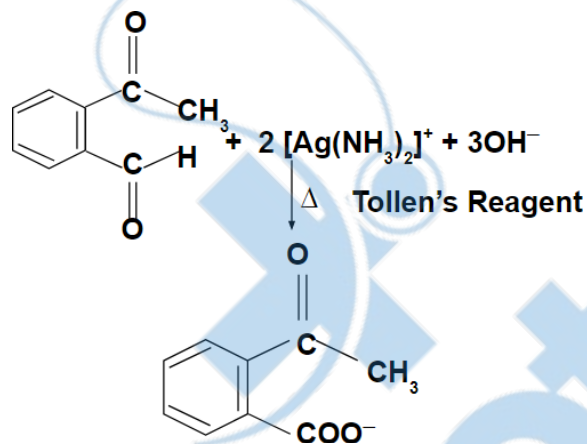

Question 88: Which of the following statements are INCORRECT?

- A. All the transition metals except scandium form MO oxides which are ionic.
- B. The highest oxidation number corresponding to the group number in transition metal oxides is attained in Sc_2O_3 to Mn_2O_7 .
- C. Basic character increases from V_2O_3 to V_2O_4 to V_2O_5 .
- D. V_2O_4 dissolves in acids to give VO_4^{3-} salts.
- E. CrO is basic but Cr_2O_3 is amphoteric.

Choose the correct answer from the options given below:

Options:

- (a) A and E only
- (b) B and D only
- (c) C and D only
- (d) B and C only

Answer: (c)

Solution: V_2O_4 dissolves in acids to give VO^{2+} salts

D is wrong

As O.N.O. \uparrow acidic character \uparrow

Basic nature : $\text{V}_2\text{O}_3 > \text{V}_2\text{O}_4 > \text{V}_2\text{O}_5$

Question 89: Which amongst the following be most readily dehydrated under acidic conditions?

Options:

(a)

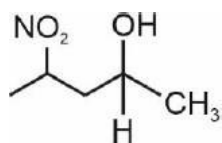

(b)

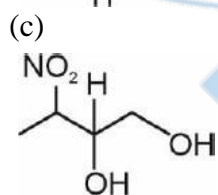
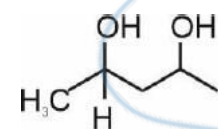

Answer: (d)

Solution:



Most stable carbocation as -I of NO_2 is minimum and 5 α -H

So hence undergo dehydration easily

Question 90: Consider the following reaction :

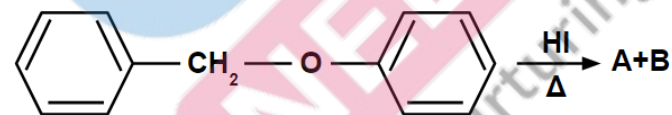

Options:

(a)

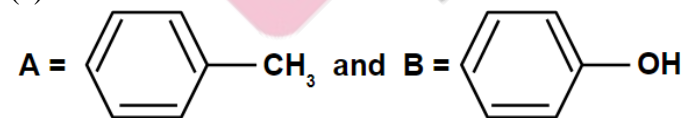

(b)

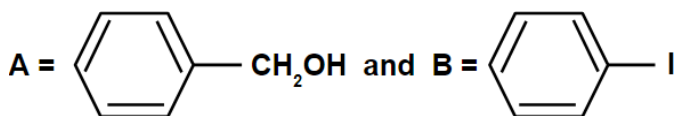

(c)

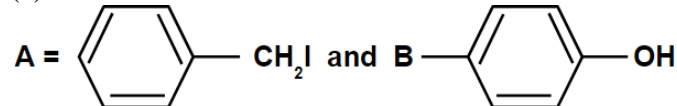

(d)

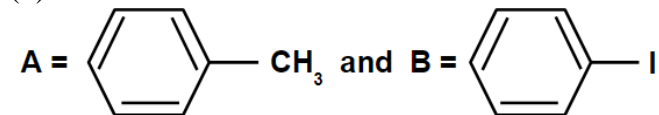

Answer: (c)

Solution:

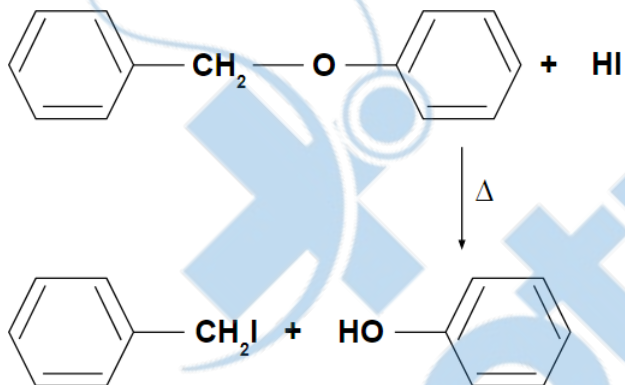

Question 91: The reaction that does NOT take place in a blast furnace between 900 K to 1500 K temperature range during extraction of iron is :

Options:

- (a) $\text{Fe}_2\text{O}_3 + \text{CO} \rightarrow 2\text{FeO} + \text{CO}_2$
- (b) $\text{FeO} + \text{CO} \rightarrow \text{Fe} + \text{CO}_2$
- (c) $\text{C} + \text{CO}_2 \rightarrow 2\text{CO}$
- (d) $\text{CaO} + \text{SiO}_2 \rightarrow \text{CaSiO}_3$

Answer: (a)

Solution: The reactions that take place in a blast furnace between 900 k to 1500 k are:

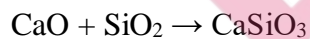
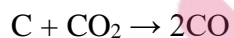
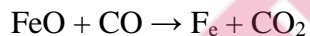

Question 92: Which amongst the following options is the correct relation between change in enthalpy and change in internal energy?

Options:

- (a) $\Delta H = \Delta U - \Delta n_g RT$
- (b) $\Delta H = \Delta U + \Delta n_g RT$
- (c) $\Delta H - \Delta U = -\Delta n RT$
- (d) $\Delta H + \Delta U = \Delta n R$

Answer: (b)

Solution: $\Delta H = \Delta U + \Delta n_g RT$

Question 93: On balancing the given redox reaction,

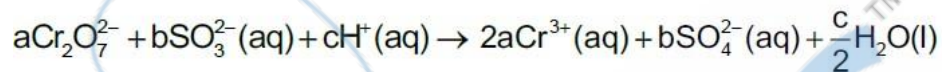

the coefficients a, b and c are found to be, respectively-

Options:

- (a) 1, 3, 8
- (b) 3, 8, 1
- (c) 1, 8, 3
- (d) 8, 1, 3

Answer: (a)



Question 94: What fraction of one edge centred octahedral void lies in one unit cell of fcc?

Options:

- (a) $\frac{1}{2}$
- (b) $\frac{1}{3}$
- (c) $\frac{1}{4}$
- (d) $\frac{1}{12}$

Answer: (c)



Question 95: Given below are two statements :

Statement I: The nutrient deficient water bodies lead to eutrophication

Statement II: Eutrophication leads to decrease in the level of oxygen in the water bodies.

In the light of the above statements, choose the correct answer from the options given below:

Options:

- (a) Both Statement I and Statement II are true
- (b) Both Statement I and Statement II are false
- (c) Statement I is correct but Statement II is false
- (d) Statement I is incorrect but Statement II is true

Answer: (d)

Solution: Eutrophication is a process in which nutrient enriched water bodies support a dense plant population which kills animal life by depriving it of O₂ and results in loss of biodiversity.

Question 96: The equilibrium concentrations of the species in the reaction $\text{A} + \text{B} \rightleftharpoons \text{C} + \text{D}$ are 2, 3, 10 and 6 mol L⁻¹, respectively at 300 K. ΔG° for the reaction is (R = 2 cal/mol K)

Options:

- (a) 1372.60 cal
 (b) -137.26 cal
 (c) -1381.80 cal
 (d) -13.73 cal

Answer: (c)**Solution:** -1381.80 cal**Question 97:** Which complex compound is most stable?**Options:**

(a)

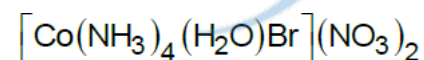

(b)

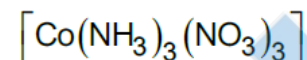

(c)

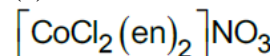

(d)

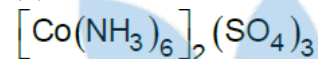
**Answer: (c)****Solution:** Since there are two 5-membered rings (Chelation) $[\text{CoCl}_2(\text{en})_2]\text{NO}_3$ will be most stable**Question 98:** Match List-I with List-II :

List-I (Oxoacids of Sulphur)	List-II (Bonds)
A. Peroxodisulphuric acid	I. Two S-OH, Four S=O, One S-O-S
B. Sulphuric acid	II. Two S-OH, One S=O
C. Pyrosulphuric acid	III. Two S-OH, Four S=O, One S-O-O-S
D. Sulphurous acid	IV. Two S-OH, Two S=O

Choose the correct answer from the options given below.

Options:

- (a) A-I, B-III, C-II, D-IV
 (b) A-III, B-IV, C-I, D-II
 (c) A-I, B-III, C-IV, D-II
 (d) A-III, B-IV, C-II, D-I

Answer: (b)**Solution:** A-III, B-IV, C-I, D-II**Question 99:** Pumice stone is an example of**Options:**

- (a) Sol
 (b) Gel
 (c) Solid sol
 (d) Foam

Answer: (c)

Solution: Solid sol

Question 100: Identify the final product [D] obtained in the following sequence of reactions.

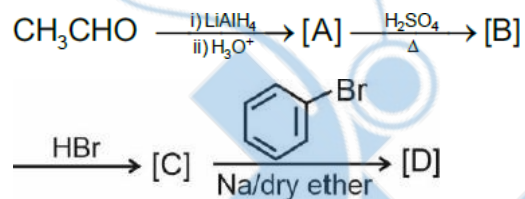

Options:

(a)

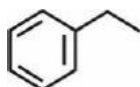

(b)

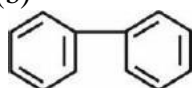

(c) C₄H₁₀

(d)



Answer: (a)

Solution:

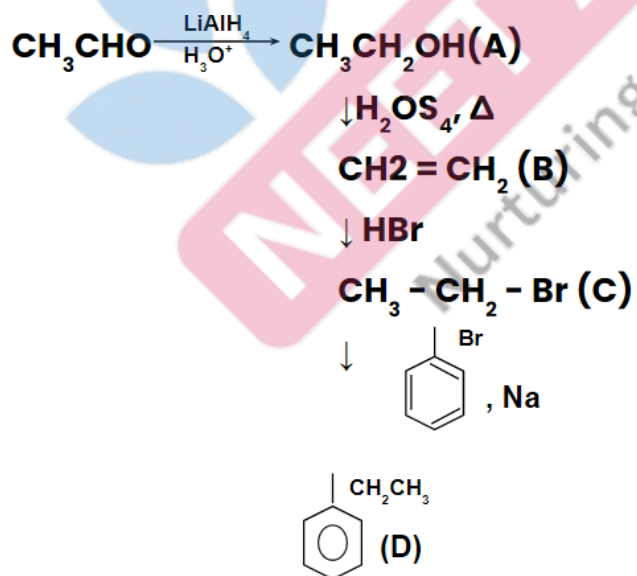

NEET 2023

Biology

Question 101: Given below are two statements:

Statement I: The forces generated by transpiration can lift a xylem-sized column of water over 130 meters height.

Statement II: Transpiration cools leaf surfaces sometimes 10 to 15 degrees, by evaporating cooling.

In the light of the above statements, choose the **most appropriate** answer from the options given below:

Options:

- (a) Both Statement I and Statement II are correct.
- (b) Both Statement I and Statement II are not correct.
- (c) Statement I is correct but Statement II is incorrect.
- (d) Statement I is incorrect but Statement II is correct.

Answer: (a)

Question 102: In gene gun method used to introduce alien DNA into host cells, microparticles of _____ metal are used.

Options:

- (a) Copper
- (b) Zinc
- (c) Tungsten or gold
- (d) Silver

Answer: (c)

Question 103: Given below are two statements: One is labelled as **Assertion A** and the other is labelled as **Reason R**:

Assertion A: The first stage of gametophyte in the life cycle of moss is protonema stage.

Reason R: Protonema develops directly from spores produced in capsule.

In the light of the above statements, choose the **most appropriate** answer from the options given below:

Options:

- (a) Both A and R are correct and R is the correct explanation of A.
- (b) Both A and R are correct but R is NOT the correct explanation of A.
- (c) A is correct but R is not correct.
- (d) A is not correct but R is correct.

Answer: (a)

Question 104: Unequivocal proof that DNA is the genetic material was first proposed by

Options:

- (a) Frederick Griffith
- (b) Alfred Hershey and Martha Chase
- (c) Avery, Macleoid and McCarthy
- (d) Wilkins and Franklin

Answer: (b)

Question 105: The thickness of ozone in a column of air in the atmosphere is measured in terms of:

Options:

- (a) Dobson units
- (b) Decibels
- (c) Decameter
- (d) Kilobase

Answer: (a)

Question 106: In tissue experiments, leaf mesophyll cells are put in a culture medium to form callus. This phenomenon may be called as:

Options:

- (a) Differentiation
- (b) Dedifferentiation
- (c) Development
- (d) Senescence

Answer: (b)

Question 107: Large, colourful, fragrant flowers with nectar are seen in:

Options:

- (a) insect pollinated plants
- (b) bird pollinated plants
- (c) bat pollinated plants
- (d) wind pollinated plants

Answer: (a)

Question 108: Frequency of recombination between gene pairs on some chromosome as a measure of the distance between genes to map their position on chromosome, was used for the first time by

Options:

- (a) Thomas Hunt Morgan
- (b) Sutton and Boveri
- (c) Alfred Sturtevant
- (d) Henking

Answer: (c)

Question 109: Which of the following stages of meiosis involves division of centromere?

Options:

- (a) Metaphase I
- (b) Metaphase II
- (c) Anaphase II
- (d) Telophase

Answer: (c)

Question 110: What is the role of RNA polymerase III in the process of transcription in Eukaryotes?

Options:

- (a) Transcription of rRNAs (28S, 18S and 5.8S)
- (b) Transcription of tRNA, 5srRNA and snRNA
- (c) Transcription of precursor of mRNA

(d) Transcription of only snRNAs

Answer: (b)

Question 111: Among 'The Evil Quartet' which one is considered the most important cause driving extinction of species?

Options:

- (a) Habitat loss and fragmentation
- (b) Over exploitation for economic gain
- (c) Alien species invasions
- (d) Co-extinctions

Answer: (a)

Question 112: Given below are two statements:

Statement I: Endarch and exarch are the terms often used for describing the position of secondary xylem in the plant body.

Statement II: Exarch condition is the most common feature of the root system

In the light of the above statements, choose the **correct** answer from the options given below:

Options:

- (a) Both Statement I and Statement II are true.
- (b) Both Statement I and Statement II are not false.
- (c) Statement I is correct but Statement II is false.
- (d) Statement I is incorrect but Statement II is true.

Answer: (d)

Question 113: Axile placentation is observed in

Options:

- (a) Mustard, Cucumber and Primrose
- (b) China rose, Beans and Lupin
- (c) Tomato, Dianthus and Pea
- (d) China rose, Petunia and Lemon

Answer: (d)

Question 114: Expressed Sequence Tags (ESTs) refers to

Options:

- (a) All genes that are expressed as RNA.
- (b) All genes that are expressed as proteins.
- (c) All genes whether expressed or unexpressed.
- (d) Certain important expressed genes.

Answer: (a)

Question 115: What is the function of tassels in the corn cob?

Options:

- (a) To attract insects
- (b) To trap pollen grains
- (c) To disperse pollen grains
- (d) To protect seeds

Answer: (b)

Question 116: Spraying of which of the following phytohormone on juvenile conifers helps in hastening the maturity period, that leads to early seed production?

Options:

- (a) Indole-3-butyric Acid
- (b) Gibberellic Acid
- (c) Zeatin
- (d) Abscisic Acid

Answer: (b)

Question 117: In the equation

$$\boxed{GPP - R - NPP}$$

GPP is Gross Primary Productivity

NPP is Net Primary Productivity

R here is _____.

Options:

- (a) Photosynthetically active radiation
- (b) Respiratory quotient
- (c) Respiratory loss
- (d) Reproductive allocation

Answer: (c)

Question 118: Family Fabaceae differs from Solanaceae and Liliaceae. With respect to the stamens, pick out the characteristics specific to family Fabaceae but not found in Solanaceae or Liliaceae.

Options:

- (a) Diadelphous and Ditheous anthers
- (b) Polyadelphous and epipetalous stamens
- (c) Monoadelphous and Monotheous anthers
- (d) Epiphylous and Ditheous anthers

Answer: (a)

Question 119: In angiosperm, the haploid, diploid and triploid structures of a fertilized embryo sac sequentially are:

Options:

- (a) Synergids, Primary endosperm nucleus and zygote
- (b) Antipodals, synergids, and primary endosperm nucleus
- (c) Synergids, Zygote and Primary endosperm nucleus
- (d) Synergids, antipodals and Polar nuclei

Answer: (c)

Question 120: Which hormone promotes internode/petiole elongation in deep water rice?

Options:

- (a) GA₃
- (b) Kinetin
- (c) Ethylene
- (d) 2, 4-D

Answer: (c)

Question 121: Given below are two statements: One is labelled as **Assertion A** and the other is labelled as **Reason R**:

Assertion A: Late wood has fewer xylary elements with narrow vessels.

Reason R: Cambium is less active in winters.

In the light of the above statements, choose the **correct** answer from the options given below:

Options:

- (a) Both A and R are true and R is the correct explanation of A.
- (b) Both A and R are true but R is NOT the correct explanation of A.
- (c) A is true but R is not false.
- (d) A is not false but R is true.

Answer: (a)

Question 122: Given below are two statements: One is labelled as **Assertion A** and the other is labelled as **Reason R**:

Assertion A: ATP is used at two steps in glycolysis.

Reason R: First ATP is used in converting glucose into glucose-6-phosphate and second ATP is used in conversion of fructose-6-phosphate into fructose-1-6-diphosphate.

In the light of the above statements, choose the **correct** answer from the options given below:

Options:

- (a) Both A and R are true and R is the correct explanation of A.
- (b) Both A and R are true but R is NOT the correct explanation of A.
- (c) A is true but R is not false.
- (d) A is not false but R is true.

Answer: (a)

Question 123: Identify the **correct** statements:

- A. Detrivores perform fragmentation.
- B. The humus is further degraded by some microbes during mineralization.
- C. Water soluble inorganic nutrients go down into the soil and get precipitated by a process called leaching.
- D. The detritus food chain begins with living organisms.
- E. Earthworms break down detritus into smaller particles by a process called catabolism.

Choose the correct answer from the options given below :

Options:

- (a) A, B, C only
- (b) B, C, D only
- (c) C, D, E only
- (d) D, E, A only

Answer: (d)

Question 124: The process of appearance of recombination nodules occurs at which sub stage of prophase I in meiosis?

Options:

- (a) Zygotene
- (b) Pachytene
- (c) Diplotene
- (d) Diakinesis

Answer: (b)

Question 125: How many ATP and NADPH₂ are required for the synthesis of one molecule of Glucose during Calvin cycle?

Options:

- (a) 12 ATP and 12 NADPH₂
- (b) 18 ATP and 12 NADPH₂
- (c) 12 ATP and 16 NADPH₂
- (d) 18 ATP and 16 NADPH₂

Answer: (b)

Question 126: The phenomenon of pleiotropism refers to

Options:

- (a) presence of several alleles of a single gene controlling a single crossover.
- (b) presences of two alleles, each of the two genes controlling a single trait.
- (c) a single gene affecting multiple phenotypic expression.
- (d) more than two genes affecting a single character.

Answer: (c)

Question 127: Upon exposure to UV radiation, DNA stained with ethidium bromide will show

Options:

- (a) Bright red colour
- (b) Bright blue colour
- (c) Bright yellow colour
- (d) Bright orange colour

Answer: (d)

Question 128: The reaction centre in PS II has an absorption maxima at

Options:

- (a) 680 nm
- (b) 700 nm
- (c) 660 nm
- (d) 780 nm

Answer: (a)

Question 129: During the purification process for recombinant DNA technology, addition of chilled ethanol precipitates out

Options:

- (a) RNA
- (b) DNA
- (c) Histones
- (d) Polysaccharides

Answer: (b)

Question 130: Which micronutrient is required for splitting of water molecule during photosynthesis?

Options:

- (a) manganese
- (b) molybdenum
- (c) magnesium
- (d) copper

Answer: (a)

Question 131: Movement and accumulation of ions across a membrane against their concentration gradient can be explained by

Options:

- (a) Osmosis
- (b) Facilitated Diffusion
- (c) Passive Transport
- (d) Active transport

Answer: (d)

Question 132: Among eukaryotes, replication of DNA takes place in

Options:

- (a) M phase
- (b) S phase
- (c) G₁ phase
- (d) G₂ phase

Answer: (b)

Question 133: Cellulose does not form blue colour with Iodine because

Options:

- (a) It is a disaccharide.
- (b) It is a helical molecule.
- (c) It does not contain complex helices and hence cannot hold iodine molecules.
- (d) It breaks down when iodine reacts with it.

Answer: (c)

Question 134: The historic Convention on Biological Diversity, 'The Earth Summit' was held in Rio de Janeiro in the year:

Options:

- (a) 1985
- (b) 1992
- (c) 1986
- (d) 2002

Answer: (b)

Question 135: Identify the pair of heterosporous pteridophytes among the following:

Options:

- (a) *Lycopodium* and *Selaginella*
- (b) *Selaginella* and *Salvinia*
- (c) *Psilotum* and *Salvinia*
- (d) *Equisetum* and *Salvinia*

Answer: (b)

Question 136: Match List I with List II:

List I	List II
A. M Phase	I. Proteins are synthesized
B. G ₂ Phase	II. Inactive phase
C. G ₁ Phase	III. Interval between mitosis and initiation of DNA replication
D. G ₁ Phase	IV. Equational division

Choose the correct answer from the options given below:

Options:

- (a) A-III, B-II, C-IV, D-I
- (b) A-IV, B-II, C-I, D-III

(c) A-IV, B-I, C-II, D-III

(d) A-II, B-IV, C-I, D-III

Answer: (c)

Question 137: Match List I with List II:

List I	List II
A. Iron	I. Synthesis of auxin
B. Zinc	II. Component of nitrate reductase
C. Boron	III. Activation of catalase
D. Molybdenum	IV. Cell elongation and differentiation

Choose the correct answer from the options given below:

Options:

(a) A-III, B-II, C-I, D-IV

(b) A-II, B-III, C-IV, D-I

(c) A-III, B-I, C-IV, D-II

(d) A-II, B-IV, C-I, D-III

Answer: (c)

Question 138: Match List I with List II:

List I	List II
A. Cohesion	I. More attraction in liquid phase
B. Adhesion	II. Mutual attraction among water molecules
C. Surface tension	III. Water loss in liquid phase
D. Guttation	IV. Attraction towards polar surfaces

Choose the correct answer from the options given below:

Options:

(a) A-II, B-IV, C-I, D-III

(b) A-IV, B-III, C-II, D-I

(c) A-III, B-I, C-IV, D-II

(d) A-II, B-I, C-IV, D-III

Answer: (a)

Question 139: How many different proteins does the ribosome consist of?

Options:

(a) 80

(b) 60

(c) 40

(d) 20

Answer: (a)

Question 140: Match List I with List II:

List I	List II
A. Oxidative decarboxylation	I. Citrate synthase
B. Glycolysis	II. Pyruvate dehydrogenase
C. Oxidative phosphorylation	III. Electron transport system
D. Tricarboxylic acid cycle	IV. EMP pathway

Choose the correct answer from the options given below:

Options:

(a) A-III, B-IV, C-II, D-I

- (b) A-II, B-IV, C-I, D-III
 (c) A-III, B-I, C-II, D-IV
 (d) A-II, B-IV, C-III, D-I

Answer: (d)

Question 141: Match List I with List II:

List I (Interaction)	List II (Species A and B)
A. Mutualism	I. + (A), O(B)
B. Commensalism	II. – (A), O(B)
C. Amensalism	III. + (A), – (B)
D. Parasitism	IV. + (A), + (B)

Choose the correct answer from the options given below:

Options:

- (a) A-IV, B-II, C-I, D-III
 (b) A-IV, B-I, C-II, D-III
 (c) A-IV, B-III, C-I, D-II
 (d) A-III, B-I, C-IV, D-II

Answer: (b)

Question 142: Main steps in the formation of Recombinant DNA are given below. Arrange these steps in a correct sequence.

- A. Insertion of recombinant DNA into the host cell.
 B. Cutting of DNA at specific location by restriction enzyme.
 C. Isolation of desired DNA fragment.
 D. Amplification of gene of interest using PCR.

Choose the correct answer from the options given below:

Options:

- (a) B, C, D, A
 (b) C, A, B, D
 (c) C, B, D, A
 (d) B, D, A, C

Answer: (c)

Question 143: Given below are two statements:

Statement I: Gause's 'Competitive Exclusion Principle' states that two closely related species competing for the same resources cannot co-exist indefinitely and competitively inferior one will be eliminated eventually.

Statement II: In general, carnivores are more adversely affected by competition than herbivores. In the light of the above statements

In the light of the above statements, choose the **correct** answer from the options given below:

Options:

- (a) Both Statement I and Statement II are true.
 (b) Both Statement I and Statement II are false.
 (c) Statement I is correct but Statement II is false.
 (d) Statement I is incorrect but Statement II is true.

Answer: (c)

Question 144: Given below are two statements: One is labelled as **Assertion A** and the other is labelled as **Reason R**:

Assertion A: A flower is defined as modified shoot wherein the shoot apical meristem changes to floral meristem.

Reason R: Internode of the shoot gets condensed to produce different floral appendages laterally at successive nodes instead of leaves.

In the light of the above statements, choose the **correct** answer from the options given below:

Options:

- (a) Both A and R are true and R is the correct explanation of A.
- (b) Both A and R are true but R is NOT the correct explanation of A.
- (c) A is true but R is not false.
- (d) A is not false but R is true.

Answer: (a)

Question 145: Which of the following statements are correct about Klinefelter's Syndrome?

A. This disorder was first described by Landon Down (1866).

B. Such an individual has overall masculine development. However, the feminine development is also expressed.

C. The affected individual is short statured.

D. Physical, psychomotor and mental development is retarded.

E. Such individuals are sterile.

Choose the correct answer from the options given below:

Options:

- (a) A and B only
- (b) C and D only
- (c) B and E only
- (d) A and E only

Answer: (c)

Question 146: Melonate inhibits the growth of pathogenic bacteria by inhibiting the activity of

Options:

- (a) Succinic dehydrogenase
- (b) Amylase
- (c) Lipase
- (d) Dinitrogenase

Answer: (a)

Question 147: Which one of the following statements is **NOT** correct?

Options:

(a) The micro-organisms involved in biodegradation of organic matter in a sewage polluted water body consume a lot of oxygen causing the death of aquatic organisms.

(b) Algal blooms caused by excess of organic matter in water improve water quality and promote fisheries.

(c) Water hyacinth grows abundantly in eutrophic water bodies and leads to an imbalance in the ecosystem dynamics of the water body.

(d) The amount of some toxic substances of industrial waste increases in the organisms at successive trophic levels.

Answer: (b)

Question 148: Which of the following combinations is required for chemiosmosis?

Options:

- (a) membrane, proton pump, proton gradient, ATP synthase
- (b) membrane, proton pump, proton gradient, NADP synthase
- (c) proton pump, electron gradient, ATP synthase
- (d) proton pump, electron gradient, NADP synthase

Answer: (a)

Question 149: Identify the correct statements:

- A. Lenticels are the lens-shaped openings permitting the exchange of gases.
- B. Bark formed early in the season is called hard bark.
- C. Bark is a technical term that refers to all tissues exterior to vascular cambium.
- D. Bark refers to periderm and secondary phloem.
- E. Phellogen is single-layered in thickness.

Choose the correct answer from the options given below :

Options:

- (a) B, C and E only
- (b) A and D only
- (c) A, B and D only
- (d) B and C only

Answer: (b)

Question 150: Given below are two statements: One is labelled as **Assertion A** and the other is labelled as **Reason R**:

Assertion A: In gymnosperms the pollen grains are released from the microsporangium and carried by air currents.

Reason R: Air currents carry the pollen grains to the mouth of the archegonia where the gametes are discharged and pollen tube is not formed.

In the light of the above statements, choose the **correct** answer from the options given below:

Options:

- (a) Both A and R are true and R is the correct explanation of A.
- (b) Both A and R are true but R is NOT the correct explanation of A.
- (c) A is true but R is not false.
- (d) A is not false but R is true.

Answer: (c)

Question 151: Which of the following is not a cloning vector?

Options:

- (a) BAC
- (b) YAC
- (c) pBR322
- (d) Probe

Answer: (d)

Question 152: Broad palm with single palm crease is visible in a person suffering from

Options:

- (a) Down's syndrome
- (b) Turner's syndrome
- (c) Klinefelter's syndrome
- (d) Thalassemia

Answer: (a)

Question 153: Which of the following are NOT considered as the part of endomembrane system?

- A. Mitochondria
- B. Endoplasmic Reticulum
- C. Chloroplasts
- D. Golgi complex
- E. Peroxisomes

Choose the **most appropriate** answer from the options given below:

Options:

- (a) B and D only
- (b) A, C and E only
- (c) A and D only
- (d) A, D and E only

Answer: (b)

Question 154: Match List I with List II:

List I	List II
A. <i>Taenia</i>	I. Nephridia
B. <i>Paramoecium</i>	II. Contractile vacuole
C. <i>Periplaneta</i>	III. Flame cells
D. <i>Pheretima</i>	IV. Urecose gland

Choose the correct answer from the options given below:

Options:

- (a) A-I, B-II, C-III, D-IV
- (b) A-I, B-II, C-IV, D-III
- (c) A-III, B-II, C-IV, D-I
- (d) A-II, B-I, C-IV, D-III

Answer: (c)

Question 155: Given below are two statements: One is labelled as **Assertion A** and the other is labelled as **Reason R**:

Assertion A: Amniocentesis for sex determination is one of the strategies of Reproductive and Child Health Care programme.

Reason R: Ban on aminocentesis checks increasing menace of female foeticide

In the light of the above statements, choose the **correct** answer from the options given below:

Options:

- (a) Both A and R are true and R is the correct explanation of A.
- (b) Both A and R are true but R is NOT the correct explanation of A.
- (c) A is true but R is not false.
- (d) A is false but R is true.

Answer: (d)

Question 156: Given below are two statements:

Statement I: Ligaments are dense irregular tissue.

Statement II: Cartilage is dense regular tissue.

In the light of the above statements, choose the **correct** answer from the options given below:

Options:

- (a) Both Statements I and II are true
- (b) Both statements I and II are false
- (c) Statement I is true but Statement II is false
- (d) Statement I is false, but Statement II is true

Answer: (b)

Question 157: Match List I with List II:

List I	List II
A. P-wave	I. Beginning of systole
B. Q-wave	II. Repolarisation of ventricles
C. QRS complex	III. Depolarisation of atria
D. T-wave	IV. Depolarisation of ventricles

Choose the **correct** answer from the options given below:

Options:

- (a) A-III, B-I, C-IV, D-II
- (b) A-IV, B-III, C-II, D-I
- (c) A-II, B-IV, C-I, D-III
- (d) A-I, B-II, C-III, D-IV

Answer: (a)

Question 158: Match List I with List II:

List I (Cells)	List II (Secretion)
A. Peptic cells	I. Mucus
B. Goblet cells	II. Bile juice
C. Oxyntic cells	III. Proenzyme pepsinogen
D. Hepatic cells	IV. HCl and intrinsic factor for absorption of vitamin B ₁₂

Choose the **correct** answer from the options given below:

Options:

- (a) A-IV, B-III, C-I, D-I
- (b) A-II, B-I, C-III, D-IV
- (c) A-III, B-I, C-IV, D-II
- (d) A-II, B-IV, C-I, D-III

Answer: (c)

Question 159: Match List I with List II:

List I	List II
A. Vasectomy	I. Oral method
B. Coitus interrupts	II. Barrier method
C. Cervical caps	III. Surgical method
D. Saheli	IV. Natural method

Choose the **correct** answer from the options given below:

Options:

- (a) A-III, B-I, C-IV, D-II
- (b) A-III, B-IV, C-I, D-I

(c) A-II, B-III, C-I, D-IV

(d) A-IV, B-II, C-I, D-III

Answer: (b)

Question 160: Given below are two statements:

Statement I: Vas deferens receives a duct from seminal vesicle and opens into urethra as the ejaculatory duct.

Statement II: The cavity of the cervix is called cervical canal which along with vagina forms birth canal. In the light of the above statements

In the light of the above statements, choose the **correct** answer from the options given below:

Options:

(a) Both Statements I and II are true.

(b) Both statements I and II are false.

(c) Statement I is true but Statement II is false.

(d) Statement I is false, but Statement II is true.

Answer: (a)

Question 161: Given below are two statements: One is labelled as **Assertion A** and the other is labelled as **Reason R:**

Assertion A: Nephrons are of two types: Cortical & Juxta medullary, based on their relative position in cortex and medulla.

Reason R: Juxta medullary nephrons have short loop of Henle whereas, cortical nephrons have longer loop of Henle.

In the light of the above statements, choose the **correct** answer from the options given below:

Options:

(a) Both A and R are true and R is the correct explanation of A.

(b) Both A and R are true but R is NOT the correct explanation of A.

(c) A is true but R is not false.

(d) A is not false but R is true.

Answer: (c)

Question 162: Given below are two statements:

Statement I: Low temperature preserves the enzyme in a temporarily inactive state whereas high temperature destroys enzymatic activity because proteins are denatured by heat.

Statement II: When the inhibitor closely resembles the substrate in its molecular structure and inhibits the activity of the enzyme, it is known as competitive inhibitor.

In the light of the above statements, choose the **correct** answer from the options given below:

Options:

(a) Both Statements I and II are true.

(b) Both statements I and II are false.

(c) Statement I is true but Statement II is false.

(d) Statement I is false, but Statement II is true.

Answer: (a)

Question 163: Match List I with List II:

List I	List II
A. Gene 'a'	I. β -galactosidase
B. Gene 'y'	II. Transacetylase
C. Gene 'i'	III. Permease
D. Gene 'z'	IV. Repressor protein

Choose the **correct** answer from the options given below:

Options:

- (a) A-II, B-I, C-IV, D-III
- (b) A-II, B-III, C-IV, D-I
- (c) A-III, B-IV, C-I, D-II
- (d) A-III, B-I, C-IV, D-II

Answer: (b)

Question 164: Match List I with List II:

List I	List II
A. Ringworm	I. <i>Haemophilus influenzae</i>
B. Filariasis	II. <i>Trichophyton</i>
C. Malaria	III. <i>Wuchereria bancrofti</i>
D. Pneumonia	IV. <i>Plasmodium vivax</i>

Choose the **correct** answer from the options given below:

Options:

- (a) A-II, B-III, C-IV, D-I
- (b) A-II, B-III, C-I, D-IV
- (c) A-III, B-II, C-I, D-IV
- (d) A-III, B-II, C-IV, D-I

Answer: (a)

Question 165: Which of the following functions is carried out by cytoskeleton in a cell?

Options:

- (a) Nuclear division
- (b) Protein synthesis
- (c) Motility
- (d) Transportation

Answer: (c)

Question 166: Which of the following statements is correct?

Options:

- (a) Eutrophication refers to increase in domestic sewage and waste water in lakes.
- (b) Biomagnification refers to increase in concentration of the toxicant at successive trophic levels.
- (c) Presence of large amount of nutrients in water restricts 'Algal Bloom'
- (d) Algal Bloom decreases fish mortality

Answer: (b)

Question 167: Match List I with List II:

List I	List II
A. Heroin	I. Effect on cardiovascular system
B. Marijuana	II. Slow down body function
C. Cocaine	III. Painkiller
D. Morphine	IV. Interfere with transport of dopamine

Choose the **correct** answer from the options given below:

Options:

- (a) A-II, B-I, C-IV, D-III
- (b) A-I, B-II, C-III, D-IV
- (c) A-IV, B-III, C-II, D-I

(d) A-III, B-IV, C-I, D-II

Answer: (a)

Question 168: Radial symmetry is NOT found in adults of phylum_____.

Options:

- (a) Ctenophora
- (b) Hemichordata
- (c) Coelenterata
- (d) Echinodermata

Answer: (b)

Question 169: Given below are two statements:

Statement I: In prokaryotes, the positively charged DNA is held with some negatively charged proteins in a region called nucleoid.

Statement II: In eukaryotes, the negatively charged DNA is wrapped around the positively charged histone octamer to form nucleosome. In the light of the above statements

In the light of the above statements, choose the **correct** answer from the options given below:

Options:

- (a) Both Statements I and Statement II are true.
- (b) Both statements I and Statement II are false.
- (c) Statement I is correct but Statement II is false.
- (d) Statement I is incorrect but Statement II is true.

Answer: (d)

Question 170: Which of the following statements are correct regarding female reproductive cycle?

- A. In non-primate mammals cyclical changes during reproduction are called oestrus cycle.
- B. First menstrual cycle begins at puberty and is called menopause.
- C. Lack of menstruation may be indicative of pregnancy.
- D. Cyclic, menstruation extends between menarche and menopause.

Choose the **most appropriate** answer from the options given below:

Options:

- (a) A and D only
- (b) A and B only
- (c) A, B and C only
- (d) A, C and D only

Answer: (d)

Question 171: Select the correct group/set of Australian Marsupials exhibiting adaptive radiation.

Options:

- (a) Tasmanian wolf, Bobcat, Marsupial mole
- (b) Numbat, Spotted cuscus, Flying phalanger
- (c) Mole, Flying squirrel, Tasmanian tiger cat
- (d) Lemur, Anteater, Wolf

Answer: (b)

Question 172: Which one of the following techniques does not serve the purpose of early diagnosis of a disease for its early treatment?

Options:

- (a) Recombinant DNA Technology
- (b) Serum and Urine analysis
- (c) Polymerase Chain Reaction (PCR) technique
- (d) Enzyme Linked Immuno-Sorbent Assay (ELISA) technique

Answer: (b)

Question 173: Match List I with List II:

List I (Type of Joint)	List II (Found between)
A. Cartilaginous Joint	I. Between flat skull bones
B. Ball and Socket Joint	II. Between adjacent vertebrae in vertebral column
C. Fibrous Joint	III. Between carpal and metacarpal of thumb
D. Saddle Joint	IV. Between Humerus and Pectoral Girdle

Choose the **correct** answer from the options given below:

Options:

- (a) A-III, B-I, C-II, D-IV
- (b) A-II, B-IV, C-I, D-III
- (c) A-I, B-IV, C-III, D-II
- (d) A-II, B-IV, C-III, D-I

Answer: (b)

Question 174: Match List I with List II:

List I (Interacting species)	List II (Name of Interaction)
A. A Leopard and a Lion in a forest/grassland	I. Competition
B. A Cuckoo laying egg in a Crow's nest	II. Brood parasitism
C. Fungi and root of a higher plant in Mycorrhizae	III. Mutualism
D. A cattle egret and a Cattle in a field	IV. Commensalism

Choose the **correct** answer from the options given below:

Options:

- (a) A-I, B-II, C-III, D-IV
- (b) A-I, B-II, C-IV, D-III
- (c) A-III, B-IV, C-I, D-II
- (d) A-II, B-III, C-I, D-IV

Answer: (a)

Question 175: Vital capacity of lung is_____.

Options:

- (a) IRV + ERV
- (b) IRV + ERV + TV + RV
- (c) IRV + ERV + TV - RV
- (d) IRV + ERV + TV

Answer: (d)

Question 176: Match List I with List II:

List I	List II
A. Fovea	I. Visible coloured portion of eye that regulates diameter of pupil.
B. Iris	II. External layer of eye formed of dense connective tissue.

C. Blind spot	III. Point of greatest visual acuity or resolution.
D. Sclera	IV. Point where optic nerve leaves the eyeball and photoreceptor cells are absent.

Choose the **correct** answer from the options given below:

Options:

- (a) A-III, B-I, C-IV, D-II
- (b) A-IV, B-III, C-II, D-I
- (c) A-I, B-IV, C-III, D-II
- (d) A-II, B-I, C-III, D-IV

Answer: (a)

Question 177: Once the undigested and unabsorbed substances enter the caecum, their backflow is prevented by

Options:

- (a) Sphincter of Oddi
- (b) Ileo – Caecal valve
- (c) Gastro – Oesophageal sphincter
- (d) Pyloric sphincter

Answer: (b)

Question 178: Which of the following common sexually transmitted diseases is completely curable when detected early and treated properly?

Options:

- (a) Genital herpes
- (b) Gonorrhoea
- (c) Hepatitis-B
- (d) HIV Infection

Answer: (b)

Question 179: Given below are two statements:

Statement I: A protein is imagined as a line, the left end represented by first amino acid (C-terminal) and the right end represented by last amino acid (N-terminal)

Statement II: Adult human haemoglobin, consists of 4 subunits (two subunits of α type and two subunits of β type.)

In the light of the above statements, choose the **correct** answer from the options given below:

Options:

- (a) Both Statement I and Statement II are true.
- (b) Both statement I and Statement II are false.
- (c) Statement I is correct but Statement II is false.
- (d) Statement I is incorrect but Statement II is true.

Answer: (d)

Question 180: Given below are two statements:

Statement I: Electrostatic precipitator is most widely used in thermal power plant.

Statement II: Electrostatic precipitator in thermal power plant removes ionising radiations.

In the light of the above statements, choose the **most appropriate** answer from the options given below:

Options:

- (a) Both Statement I and Statement II are true.

- (b) Both statement I and Statement II are false.
- (c) Statement I is correct but Statement II is false.
- (d) Statement I is incorrect but Statement II is true.

Answer: (c)

Question 181: In which blood corpuscles, the HIV undergoes replication and produces progeny viruses?

Options:

- (a) T_H cells
- (b) B-lymphocytes
- (c) Basophils
- (d) Eosinophils

Answer: (a)

Question 182: Given below are two statements:

Statement I: RNA mutates at a faster rate.

Statement II: Viruses having RNA genome and shorter life span mutate and evolve faster.

In the light of the above statements, choose the correct answer from the options given below:

Options:

- (a) Both Statements 1 and 2 are true
- (b) Both statements 1 and 2 are false
- (c) Statement 1 is true, but Statement 2 is false
- (d) Statement 1 is false, but Statement 2 is true

Answer: (a)

Question 183: Given below are two statements: one is labelled as Assertion A and other is labelled as Reason R.

Assertion A: Endometrium is necessary for implantation of blastocyst.

Reason R: In the absence of fertilization, the corpus luteum degenerates that causes disintegration of endometrium.

In the light of the above statements, choose the correct answer from the options given below:

Options:

- (a) Both A and R are true and R is the correct explanation of A.
- (b) Both A and R are true but R is NOT the correct explanation of A.
- (c) A is true but R is false.
- (d) A is false but It is true.

Answer: (b)

Question 184: Match List I with List II.

List I	List II
A. CCK	I. Kidney
B. GIP	II. Heart
C. ANF	III. Gastric gland
D. ADH	IV. Pancreas

Choose the correct answer from the options given below:

Options:

- (a) A-IV, B-III, C-II, D-I
- (b) A-III, B-II, C-IV, D-I
- (c) A-II, B-IV, C-I, D-III
- (d) A-IV, B-II, C-III, D-I

Answer: (a)

Question 185: Which of the following symbols represents mating between relatives in human pedigree analysis?

Options:

(a)



(b)



(c)



(d)



Answer: (b)

Question 186: The unique mammalian characteristics are:

Options:

(a) Hairs, lymphatic membrane and mammary gland

(b) hairs, pinna and mammary glands

(c) hairs, pinna and indirect development

(d) pinna, monocondylic skull and mammary glands

Answer: (b)

Question 187: Which of the following statements are correct ?

A. Basophils are most abundant cells of the total WBCs.

B. Basophils secrete histamine, serotonin and heparin.

C. Basophils are involved in inflammatory response.

D. Basophils have kidney shaped nucleus E. Basophils are agranulocytes.

Options:

(a) D and E only

(b) C and E only

(c) B and C only

(d) A and B only

Answer: (c)

Question 188: Select the correct statements with reference to chordates.

- A. Presence of a mid-dorsal, solid and double nerve cord.
- B. Presence of closed circulatory system.
- C. Presence of paired pharyngeal gillslits.
- D. Presence of dorsal heart
- E. Triploblastic pseudocoelomate animals.

Choose the correct answer from the options given below:

Options:

- (a) A, C and D only
- (b) B and C only
- (c) B, D and E only
- (d) C, D and E only

Answer: (b)

Question 189: Which of the following are NOT under the control of thyroid hormone?

- A. Maintenance of water and electrolyte balance
- B. Regulation of basal metabolic rate
- C. Normal rhythm of sleep-wake cycle
- D. Development of immune system
- E. Support the process of R.B.Cs formation

Choose the correct answer from the options given below:

Options:

- (a) A and D only
- (b) B and C only
- (c) C and D only
- (d) D and E only

Answer: (c)

Question 190: In cockroach, excretion is brought about by

- A. Phallic gland
- B. Ureose gland
- C. Nephrocytes
- D. Fat body
- E. Collateral glands

Choose the correct answer from the options given below:

Options:

- (a) A and E only
- (b) A, B and E only
- (c) B, C and D only
- (d) B and D only

Answer: (c)

Question 191: The parts of human brain that helps in regulation of sexual behaviour, expression of excitement, pleasure, rage, fear etc. are :

Options:

- (a) Limbic system & hypothalamus
- (b) Corpora quadrigemina & hippocampus
- (c) Brain stem & epithalamus
- (d) Corpus callosum and thalamus

Answer: (a)

Question 192: Match List 1 and List 2.

List 1	List 2
A. Mast cells	I. Ciliated epithelium
B. Inner surface of bronchiole	II. Areolar connective tissue
C. Blood	III. Cuboidal epithelium
D. Tubular parts of nephron	IV. Specialised connective tissue

Choose the correct answer from the options given below:

Options:

- (a) A-I, B-II, C-IV, D-III
- (b) A-II, B-III, C-I, D-IV
- (c) A-II, B-I, C-IV, D-III
- (d) A-III, B-IV, C-II, D-I

Answer: (c)

Question 193: Match List 1 and List 2.

List 1	List 2
A. Logistic growth	I. Unlimited resource availability condition
B. Exponential growth	II. Limited resource availability condition
C. Expanding age pyramid	III. The percent individuals of pre-reproductive age is largest followed by reproductive and post reproductive age groups
D. Stable age pyramid	IV. The percent individuals of pre-reproductives and reproductive age group are same

Choose the correct answer from the options given below:

Options:

- (a) A-II, B-I, C-III, D-IV
- (b) A-II, B-III, C-I, D-IV
- (c) A-II, B-IV, C-I, D-III
- (d) A-II, B-IV, C-III, D-I

Answer: (a)

Question 194: Which of the following statements are correct?

- A. An excessive loss of body fluid from the body switches off osmoreceptors.
- B. ADH facilitates water reabsorption to prevent diuresis.
- C. ANF causes vasodilation.
- D. ADH causes increase in blood pressure.
- E. ADH is responsible for decrease in GFR.

Choose the correct answer from the options given below:

Options:

- (a) A and B only
- (b) B, C and D only
- (c) A, B and E only
- (d) C, D and E only

Answer: (a)

Question 195: Given are two statements.

Statement 1: During G₀ phase of cell cycle, the cell is metabolically inactive.

Statement 2: The centrosome undergoes duplication during S phase of interphase.

In the light of the above statements, choose the most appropriate answer from the options given below:

Options:

- (a) Both Statements 1 and 2 are correct
- (b) Both statements 1 and 2 are incorrect
- (c) Statement 1 is correct, but Statement 2 is incorrect
- (d) Statement 1 is incorrect, but Statement 2 is correct

Answer: (d)

Question 196: Select the correct statements.

- A. Tetrad formation is seen during Leptotene.
- B. During Anaphase, the centromeres split and chromatids separate.
- C. Terminalization takes place during Pachytene.
- D. Nucleolus, Golgi complex and ER are reformed during Telophase.
- E. Crossing over takes place between sister chromatids of homologous chromosome.

Choose the correct answer from the options given below:

Options:

- (a) A and C only
- (b) B and D only
- (c) A, C and E only
- (d) B and E only

Answer: (b)

Question 197: Which one of the following is NOT an advantage of inbreeding?

Options:

- (a) It decreases homozygosity.
- (b) It exposes harmful recessive genes that are eliminated by selection.
- (c) Elimination of less desirable genes and accumulation of superior genes takes place due to it.
- (d) It decreases the productivity of inbred population, after continuous inbreeding.

Answer: (a)

Question 198: Which of the following is characteristic feature of cockroach regarding sexual dimorphism ?

Options:

- (a) Dark brown body colour and anal cerci
- (b) Presence of anal styles
- (c) Presence of sclerites
- (d) Presence of anal cerci

Answer: (b)

Question 199: Which one of the following is the sequence on corresponding coding strand, if the sequence on mRNA formed is as follows

5' AUCGAUCGAUCGAUCGAUCG AUCG AUCG 3'?

Options:

- (a) 5' UAGCUAGCUAGCUAGCUA GCUAGC UAGC 3'
- (b) 3' UAGCUAGCUAGCUAGCUA GCUAGCUAGC 5'
- (c) 5' ATCGATCGATCGATCGATCG ATCGATCG 3'
- (d) 3' ATCGATCGATCGATCGATCG ATCGATCG 5'

Answer: (c)

Question 200: Which of the following statements are correct regarding skeletal muscle?

- A. Muscle bundles are held together by collagenous connective tissue layer called fascicle.
- B. Sarcoplasmic reticulum of muscle fibre is a store house of calcium ions.
- C. Striated appearance of skeletal muscle fibre is due to distribution pattern of actin and myosin proteins.
- D. M line is considered as functional unit of contraction called sarcomere.

Choose the most appropriate answer from the options given below:

Options:

- (a) A, B and C only
- (b) B and C only
- (c) A, C and D only
- (d) C and D only

Answer: (a)

